



KONTI
HIDROPLAST®



**POLYPROPYLENE
KONTI RIGID
MANHOLE**

www.konti-hidroplast.com.mk



CONTENTS

INTRODUCTION.....	2
MECHANICAL PROPERTIES OF KONTI RIGID PP MANHOLES.....	5
ADVANTAGES OF KONTI RIGID PP MANHOLES.....	8
TECHNICAL SPECIFICATIONS.....	9
MAIN POINT ON MANHOLE INSTALLED UNDERGROUND TO THE GROUND LEVEL.....	10
KONTI PP RIGID MANHOLE – ARTICLE: MNH ID DN.H ID 1000.....	11
BOTTOM.....	13
BASE ID 1000.....	14
EXTENSION ID 1000 AND CONE.....	18
MANHOLE ID 800.300.....	19
BASE ID 800.....	20
EXTENSION ID 800.....	21
CONE.....	22
MANHOLE ID 600.....	22
BASE ID 600.....	23
MANHOLE ID 400.....	25
BASE ID 400.....	26
COVER.....	30
RUBBER GASKET-SEALING.....	31
MANHOLE INSTALLATION.....	34
ALL STEPS FOR MANHOLE INSTALLATION.....	35
INSTRUCTIONS FOR INSTALLATION OF PP MANHOLE.....	38
STORAGE AND TRANSPORT INSTRUCTIONS.....	40
CERTIFICATES.....	41



KONTI HIDROPLAST®

WELCOME TO OUR WORLD

Konti Hidroplast is part of the world's largest manufacturer and supplier of high performance plastic pipes and offers the best and most cost effective pipe systems for its customers.

Konti Hidroplast specializes in polyethylene pipe systems for gas and water transportation in the utilities and industrial markets.

MARKET ORIENTED

Konti Hidroplast products find a broad range of applications in the industrial and utilities market on a worldwide scale.

The water and gas distribution enterprises are important sectors for high integrity products where the maintenance of water quality and the safe transport of gaseous fuels are of paramount importance.

Industrial applications include alternative energy installations in landfill gas systems to effluent transportation and mineral slurry.

Products are widely used in pipeline installation, repair and maintenance.

Many of the brands in the Konti Hidroplast portfolio have a long record of innovation in meeting the needs of the water and gas utilities.

Being one of the foremost pioneers in polyethylene pipe systems, Konti Hidroplast is continually improving and updating its offer to meet the ever growing needs of the distribution engineer, ensuring they stay at the forefront of world gas and water distribution/treatment systems.

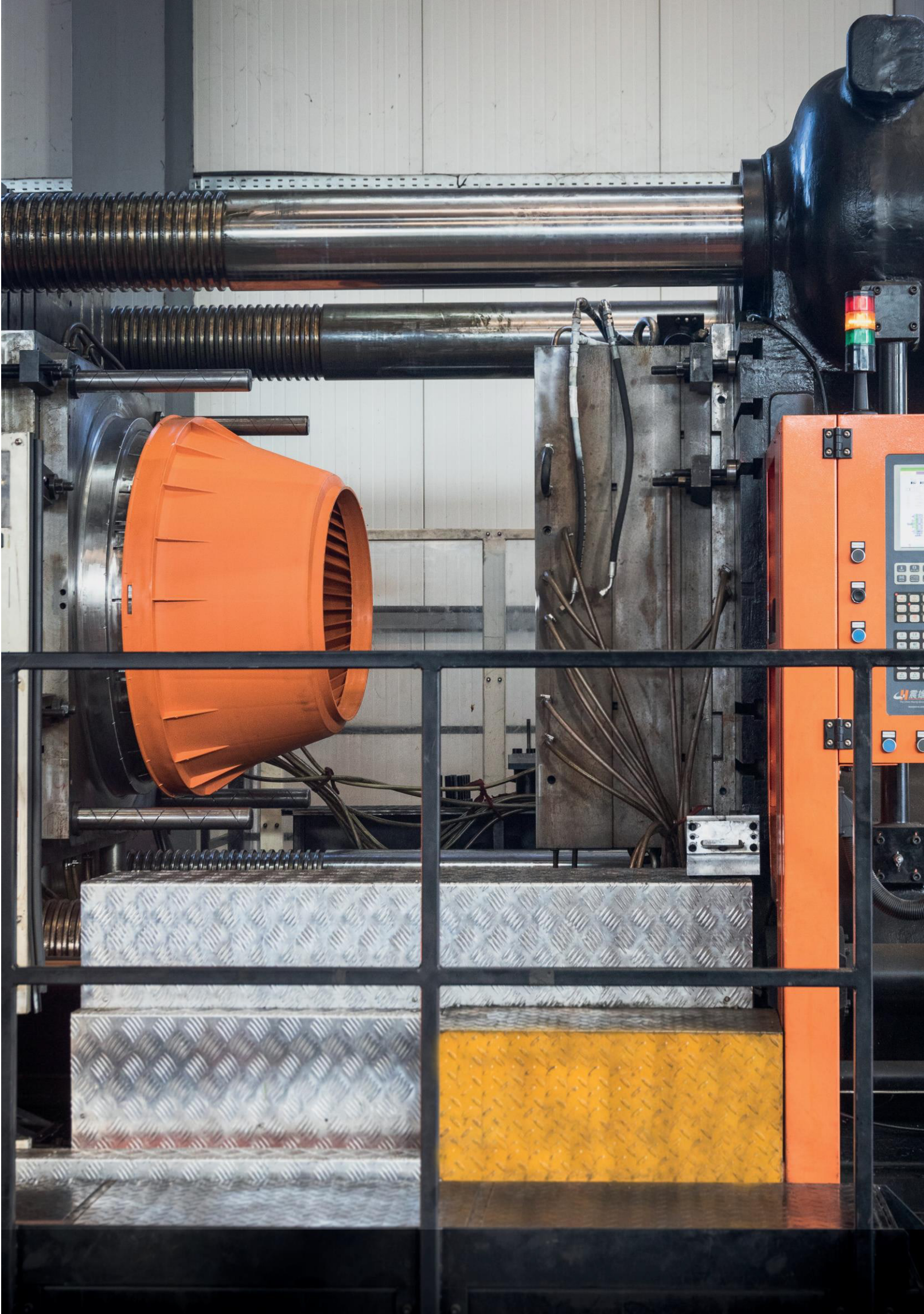



CUSTOMER FOCUS

The key to our success lies in the commitment to provide the highest quality service and support. We are a team of highly motivated and experienced individuals.

We place the utmost importance on meeting the needs of our customers, constantly evolving our extensive product portfolio to meet the ever changing demands of the water and gas utilities, industrial and foreign markets.

QUALITY

Konti Hidroplast is a result-driven business – but also a business driven by its people, products and service. Designed, manufactured and supplied under EN ISO 9001:2000 accredited Quality Management Systems, Konti Hidroplast products comply with relevant national, European and international product standards to ensure complete reliability for our customers.

Besides the ISO certificates for Quality Management Systems and ecology, the gas pipes are also certified by DVGW CERT GmbH.

THE ENVIRONMENT

Committed to sustainable manufacture and systems, Konti Hidroplast operates and maintains an environmental policy fully accredited by ISO 14001.

POLYPROPYLENE KONTI MANHOLE

MANHOLES

To offer the possibility to control and maintain the pipe system regularly, manholes are integrated in the system.

The Manhole System of Konti Hidoplast is a modern, highly developed system of chamber components. It can be used for the construction of canalization inspection chambers and inlets where the conditions are challenging. The Manhole- chamber system was designed and produced according to the latest cognitions of the plastics technology and the requirements of engineering and underground construction

Manhole system of Konti Hidoplast is multifunctional enough to offer suitable solutions for numerous problems on the construction site.

All components can be easily and quickly connected to each other as well as to other pipe systems, especially because manhole system are made of the same material as the pipes, and are also connected to the system with similar jointing techniques.

That ensures the same dimension and construction, and as a system makes a good waterproof stable and secure system.

Perfect connections and integrated sealing systems guarantee a tight connection in each area of application.



POLYPROPYLENE MANHOLE

MATERIAL PROPERTIES

Material	Polypropylene block copolymer PP-B
Short-term temperature resistance (up to 2 min.)	95-100°C
Long-term temperature resistance	60°C
Average abrasion resistance acc. to Darmstadt test	0.2 mm over a period of 50 years
Roughness coefficients: Colebrook-White (k), Hazen-Williams (C), Manning (M), after 20 years	k = 0.25, C = 150, M = 105
Chemical resistance, chemical corrosion, physical corrosion	Resistance as per ISO/TR 10358
Biological corrosion (lichens, algae and fungi)	Resistant
Additional protective coatings	Not required
Corrosive resistance to waters and sewage as per DIN 4030	Resistant to pH<4.5 (very high degree of corrosive impact on concrete)

STRUCTURE OF PRODUCTS

Water tightness	Pressure 0.5 bar, negative pressure -0.3 bar	EN ISO 13259
Nominal stiffness of chamber cores	SN 2, SN 4, SN 8 kN/m ²	ISO 13268
Impact resistance	EN 12061	EN ISO 3127
Base resistance to external load and to groundwater (up to 5 m water column)	EN 13598-2, EN14830	EN 13598-2, ISO 13267
Resistance of ladder steps to vertical load	2 kN	EN 13101
Resistance of ladder steps to horizontal pull-out load	1 kN	EN 13101
Adjustment possibility	Cutting the elements (riser pipe or the body), telescope or reinforced concrete ring	
Production process stability	High, low impact of external factors	
Wall's resistance to hydrodynamic pressure	Pressure \neq 250 bar (PRO 400 chambers), \neq 280 bar (PRO 400 G3), as per WIS 4-35-01	

USE

Uneven settlement or overload	Strain compensation, viscoelastic materials
Temperature fluctuations around 0°C	Resistance to temp. from 0°C to -20°C (EN 744)
Chamber base deformation resistance	Over 50 years, acc. to EN 13598-2, EN 14830
Material durability	Over 100 years

KONTI HIDROPLAST PP RIGID MANHOLES

Konti Hidroplast's rigid manhole is a modern solution of highly developed chamber components, used in regular as well as challenging conditions on site.

Polypropylene konti rigid manholes are produced with injection Molding technology.

The Manhole- chamber system was designed and produced according to the latest cognitions and trends of plastics technology according to all standard requirements of engineering and underground construction.

Integration of KONTI RIGID PP MANHOLES into a pipe system ensures easy access for regular inspections and maintenance, which prevents high cost damages in the longer run.

KONTI RIGID MANHOLE, if compared to the traditional concrete manholes, is lighter but stronger; thanks to the design which provides durability due to the properties of the PP material.

The assembly of the components of the manhole is easy and it does not require the use of heavy duty machinery which lowers the cost and it saves time.

APPLICATION

KONTI PP RIGID MANHOLES are intended for many varied applications and can be used as:

- Municipal and industrial manholes
- Sewer and storm water manholes
- Siphon structure
- Pump stations
- Bio treatment of sewage
- Sanitary- Sewer systems
- Landfills
- Chemical plants
- Sewage systems
- Water Meter systems

Most of the time manholes are positioned either at the beginning of the channel, where the pipeline changes dimension or direction, or there is change in the longitudinal fall.

ADVANTAGES OF KONTI RIGID PP MANHOLES

Chemical resistance – In comparison to the concrete manholes

Economic

Reduced material costs due to optimized chamber nominal diameter.

Durable

Corrosion-resistant material polypropylene increases durability and protects the environment.

100% leak-tight

Safe and inspection-friendly

Inspection-friendly color orange.

Favorable and flexible in the installation

Modular system ensures easy handling on the construction site. Lower wage and equipment costs due to weight and assembly advantages.

Built-in slope

Connection can be made with different kind of pipes

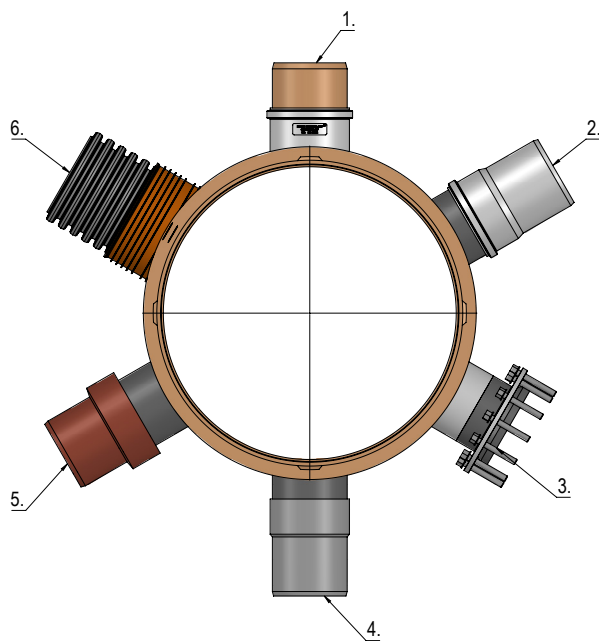

1. Polypropylene smooth pipe
2. PVC pipe
3. Cast Iron
4. GRP pipe
5. Clay pipe
6. Corrugate pipe



TECHNICAL SPECIFICATIONS

MAIN POINT ON MANHOLE INSTALLED UNDERGROUND TO THE GROUND LEVEL

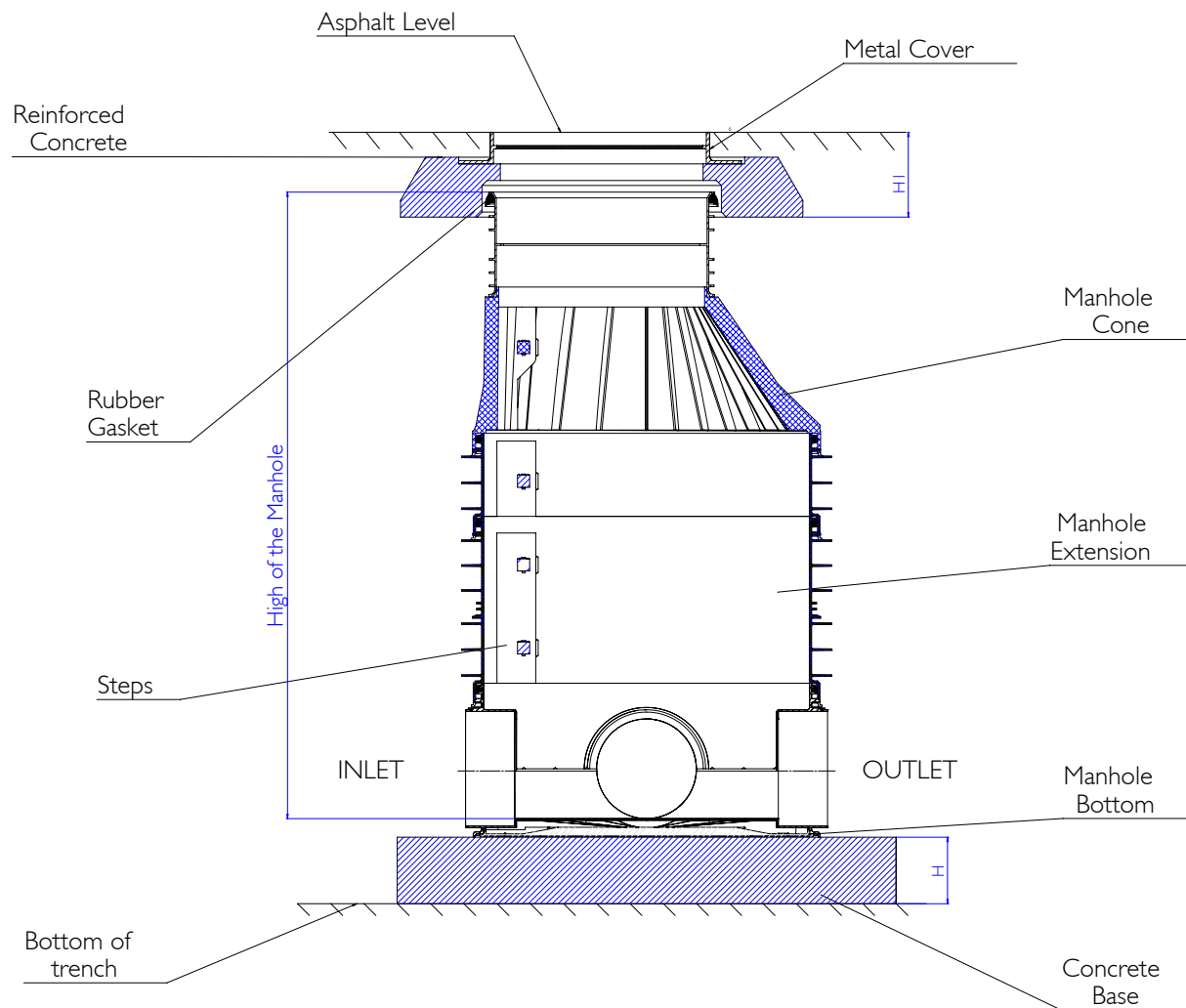

THE COMPACT STRUCTURE OF INJECTION MOLDED MANHOLE ARE RESULTS OF GOOD INTEGRATION OF ALL CONSISTING PARTS

KONTI PP RIGID MANHOLE – ARTICLE: MNH ID DN.H.

ITEM NUMB.	PART NAME
1	Bottom (BT)
2	Base (BS)
3	Extension (EXT)
4	Stairs (STR)
5	Cone (CON)

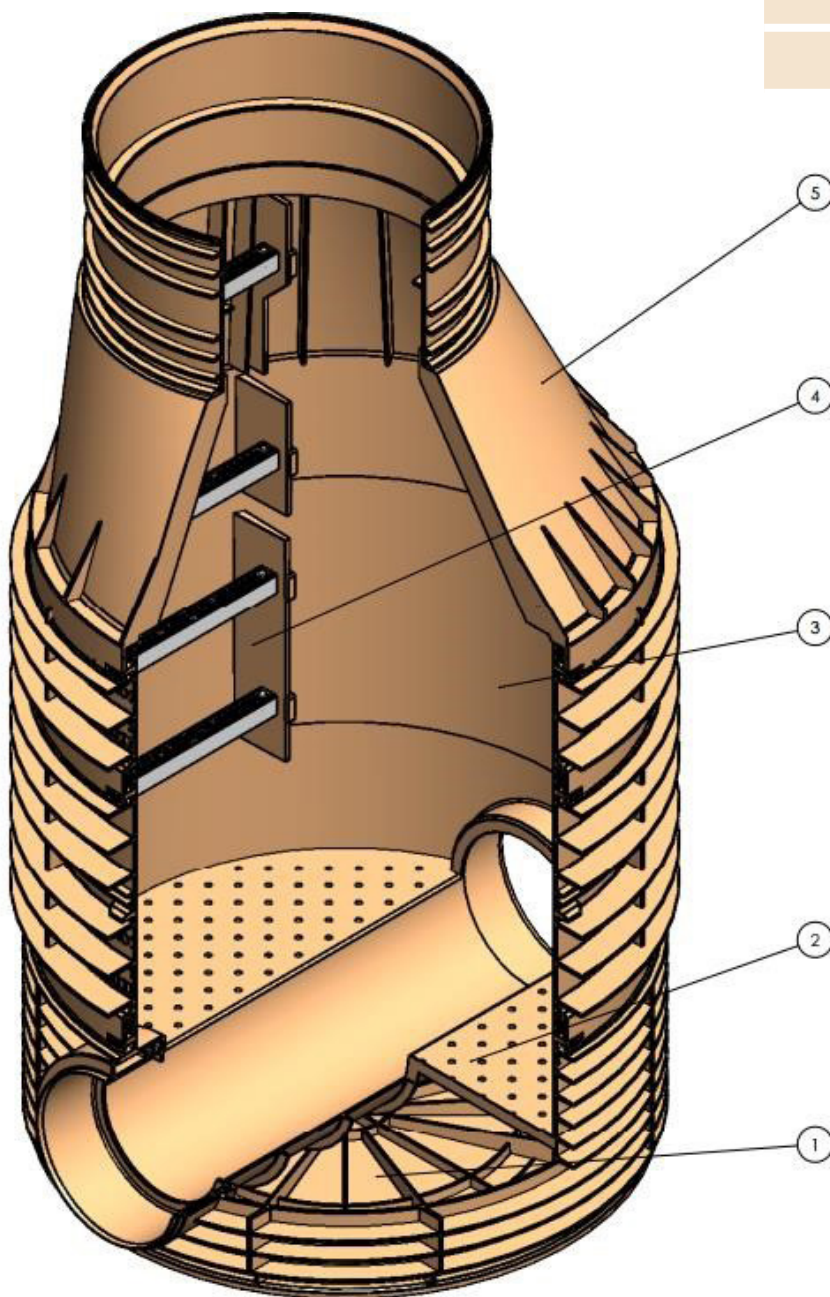

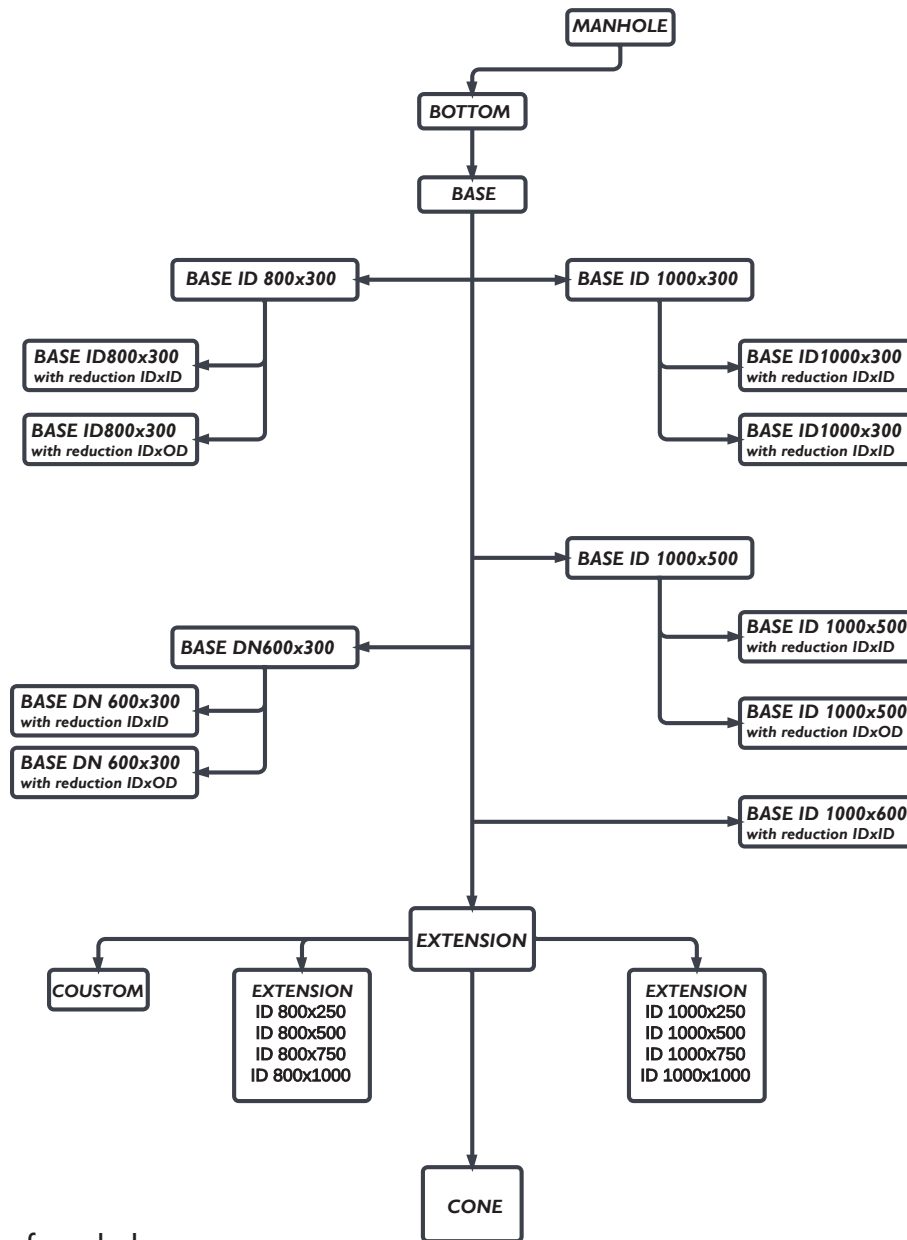

Composition of manhole:

BT - bottom,
BS - base,

EXT - extension,
CON - cone,

RD - reducer,
GASKET for part connection,
GASKET for reduction connection.

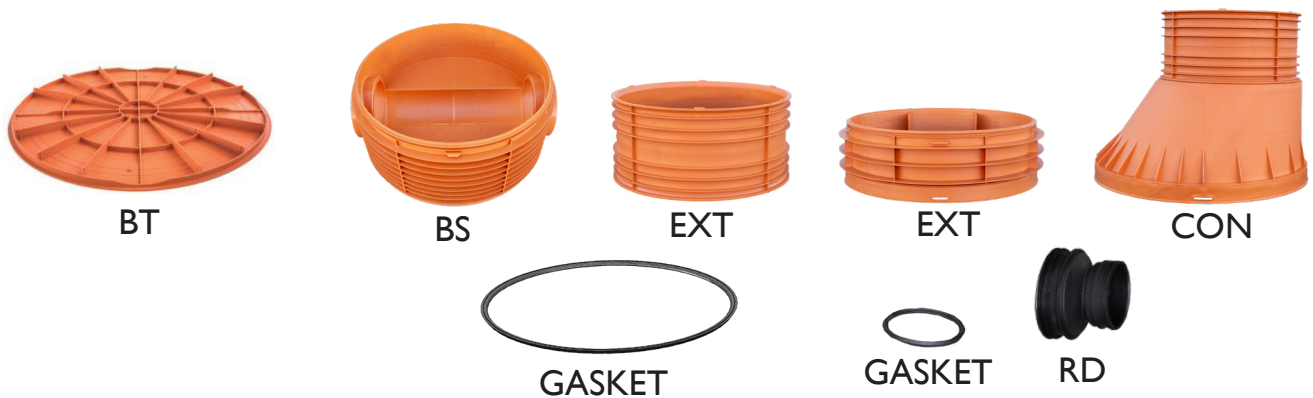

BT-BOTTOM

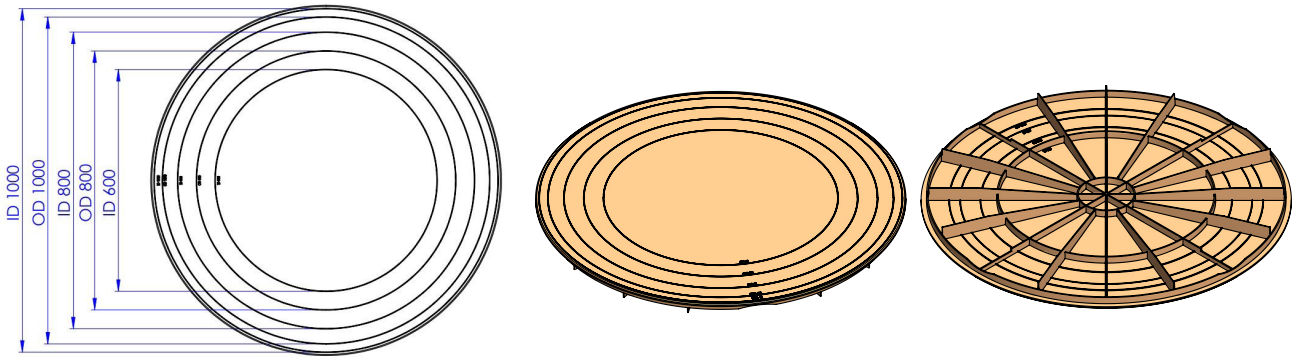

MANHOLE BOTTOM

Diameter (mm)	BT.ID 600	BT.OD 800	BT.ID 800	BT.OD 1000	BT.ID 1000
---------------	-----------	-----------	-----------	------------	------------

BS-BASE

BASE ID1000 X 300

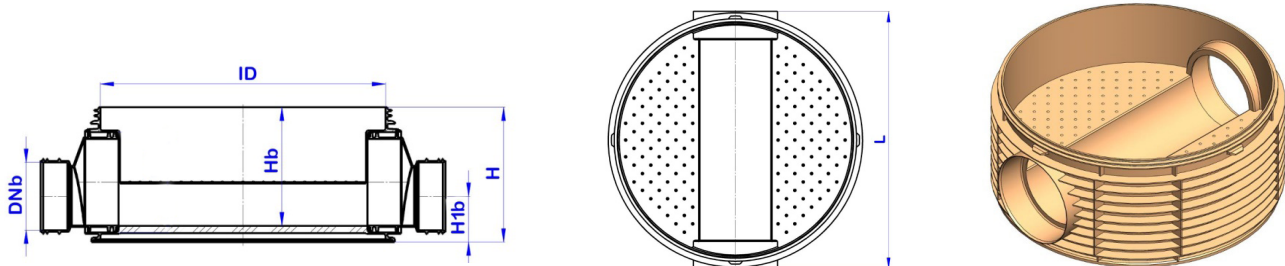

ARTICLE	DNb (mm)	ID (mm)	Hb (mm)	H (mm)	H1b (mm)	L (mm)
BS1000.300	ID300	1000	408	464	206	1086

BASE ID1000 X 4X300

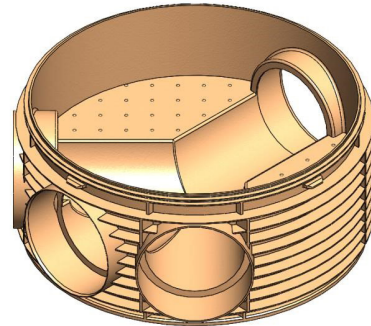
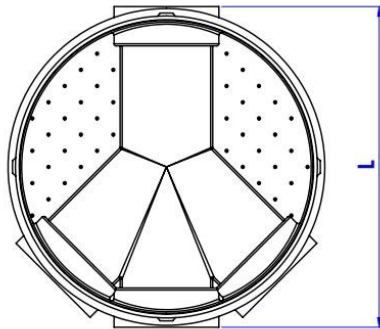

ARTICLE	DNb (mm)	ID (mm)	Hb (mm)	H (mm)	H1b (mm)	L (mm)
BS1000.300x4	ID300	1000	408	464	206	1086

BS 1000.300 – BASE ID1000 X 300 WITH REDUCTION ID X ID

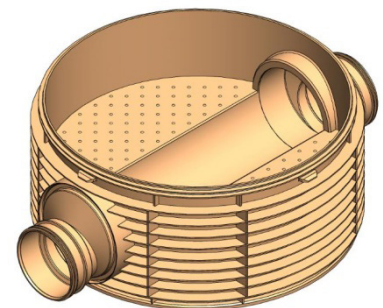
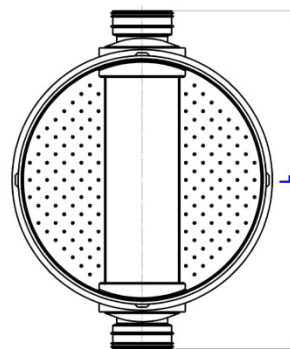
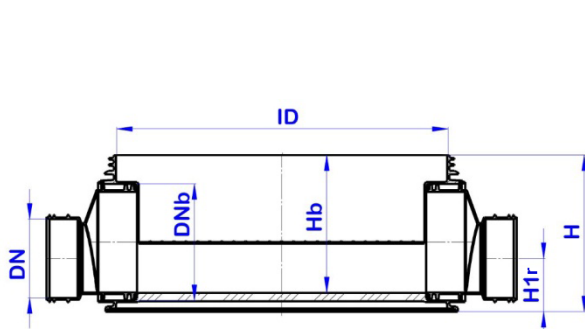

ARTICLE	DN (mm)	ID (mm)	DHb (mm)	Hb (mm)	H (mm)	H1r (mm)	L (mm)
BS1000.300.ID250	ID300xID250	1000	ID300	408	464	182	1220
BS1000.300.ID200	ID300xID200	1000	ID300	408	464	157	1238
BS1000.250.ID250	ID250xID250	1000	ID300	408	464	182	1354
BS1000.250.ID200	ID250xID200	1000	ID300	408	464	157	1372
BS1000.200.ID200	ID200xID200	1000	ID300	408	464	157	1391

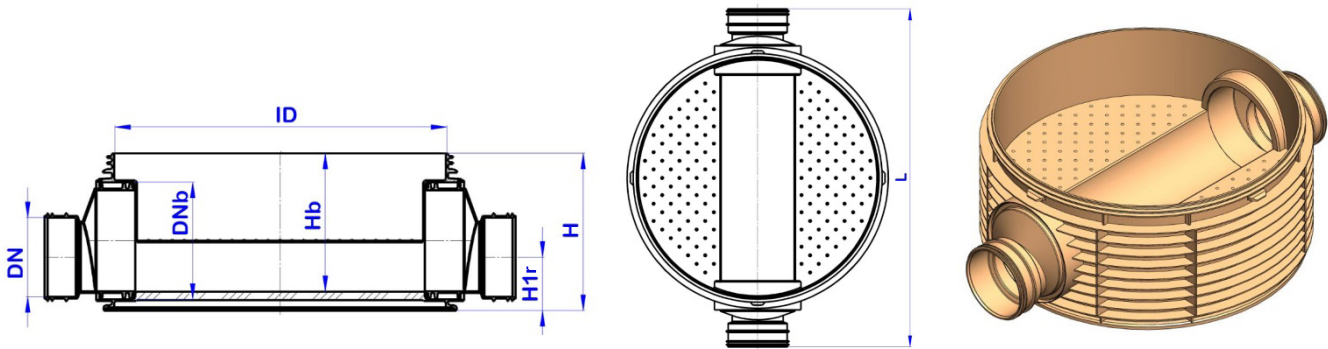
BASE ID1000 X 300 WITH REDUCTION ID X OD-BS1000.300

ARTICLE	DN (mm)	ID (mm)	DHb (mm)	Hb (mm)	H (mm)	H1r (mm)	L (mm)
BS1000.300.OD315	ID300xOD315	1000	ID300	408	464	196	1106
BS1000.300.OD250	ID300xOD250	1000	ID300	408	464	168	1374
BS1000.300.OD200	ID300xOD200	1000	ID300	408	464	146	1392
BS1000.300.OD160	ID300xOD160	1000	ID300	408	464	133	1398
BS1000.300.OD110	ID300xOD110	1000	ID300	408	464	109	1579
BS1000.250.OD250	ID250xOD250	1000	ID300	408	464	168	1364
BS1000.250.OD200	ID250xOD200	1000	ID300	408	464	146	1374
BS1000.250.OD160	ID250xOD160	1000	ID300	408	464	133	1376
BS1000.250.OD110	ID250xOD110	1000	ID300	408	464	109	1466
BS1000.200.OD200	ID200xOD200	1000	ID300	408	464	146	1392
BS1000.200.OD160	ID200xOD160	1000	ID300	408	464	133	1394
BS1000.200OD110	ID200xOD110	1000	ID300	408	464	109	1485

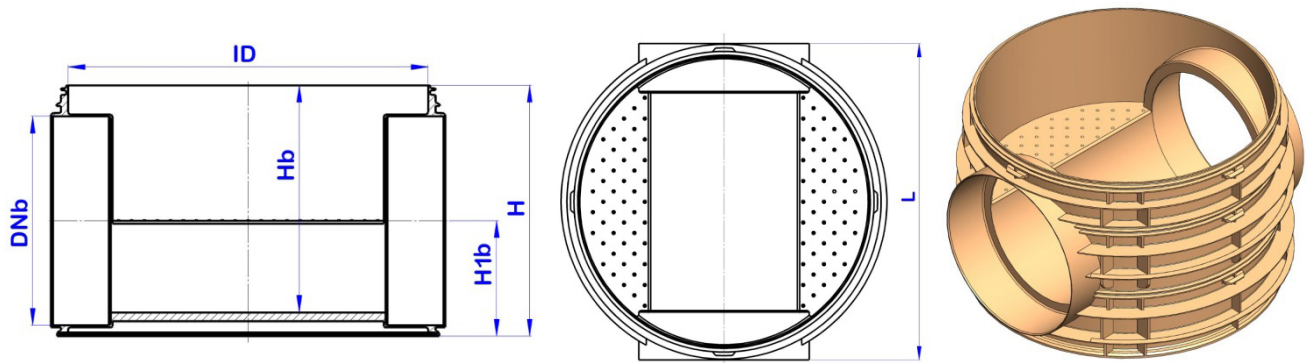
BS - BASE ID1000 X 500

ARTICLE	DNb (mm)	ID (mm)	Hb (mm)	H (mm)	H1b (mm)	L (mm)
BS1000.500	ID500	1000	620	685	315	1076

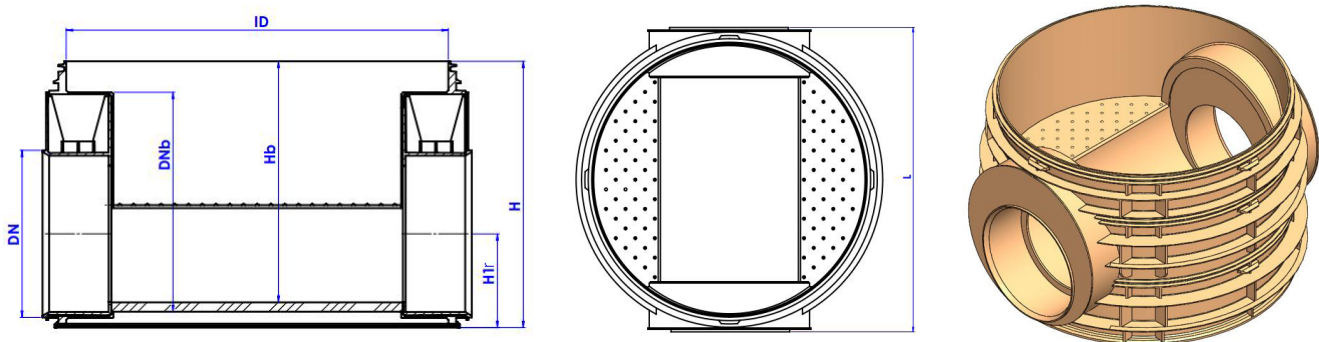
BASE ID1000 X 500 WITH REDUCTION ID X ID/IDXOD - BS1000.500

ARTICLE	DN (mm)	ID (mm)	DNb (mm)	Hb (mm)	H (mm)	H1r (mm)	L (mm)
BS1000.500.OD500	ID500XOD500	1000	ID500	620	685	241	1104
BS1000.500.ID400	ID500XID400	1000	ID500	620	685	241	1104
BS1000.500.OD400	ID500XOD400	1000	ID500	620	685	241	1104
BS1000.400.ID400	ID400XID400	1000	ID500	620	685	241	1104
BS1000.400.OD400	ID400XOD400	1000	ID500	620	685	241	1104

BASE ID1000 X 600

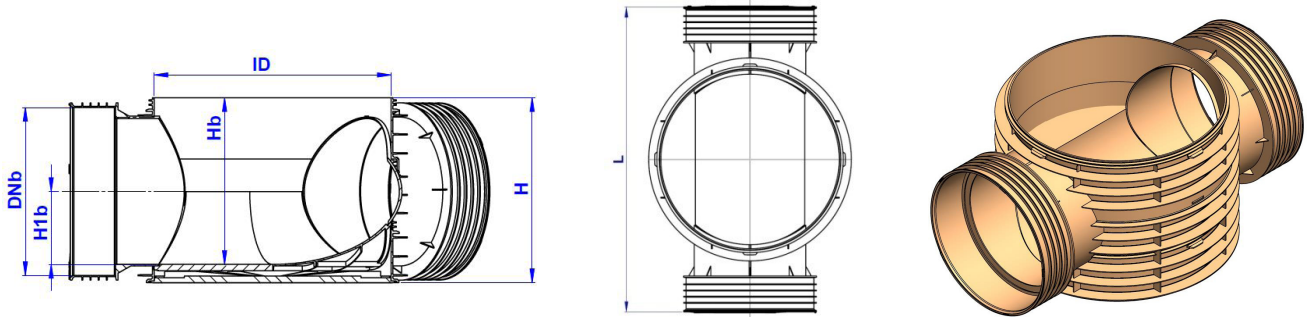

DNb (mm)	ID (mm)	Hb (mm)	H (mm)	H1b (mm)	L (mm)
BS1000.600.760	1000	684	759	300	1671
BS1000.600.1000	1000	934	1009	300	1671

BASE ID1000 X 600 (ANGLE)

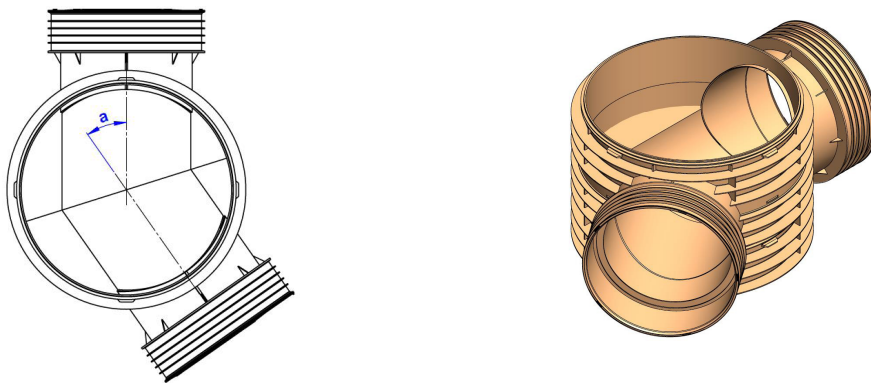

DNb (mm)	ID (mm)	Hb (mm)	H (mm)	H1b (mm)	a (°)
BS1000.760	1000	684	759	300	According to specification
BS1000.600.1000	1000	934	1009	300	According to specification

EXT-EXTENSION

EXT-EXTENSION ID 1000

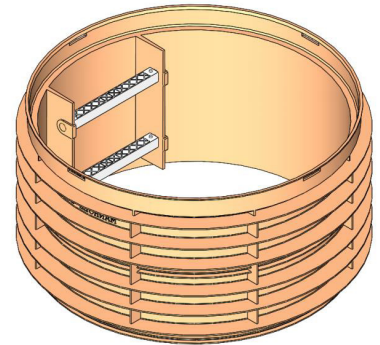
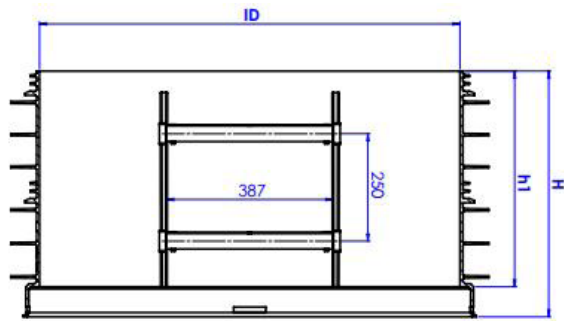

ARTICLE	ID	h1 (mm)	H (mm)
EXT 1000.250	1000	250	320
EXT 1000.500	1000	500	572
EXT 1000.750	1000	750	822
EXT 1000.1000	1000	1000	1074

CONE

CONE ID1000

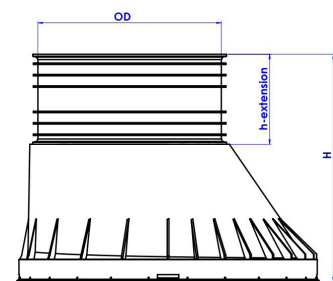
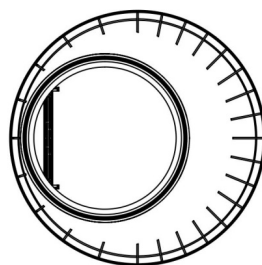
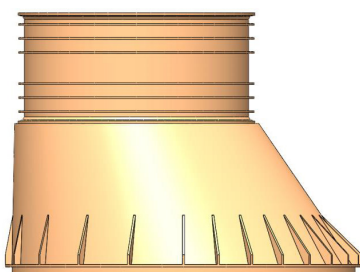

ARTICLE	ID	1000
	OD	630
	H	798
CON1000.316	h-extension	316
CON1000.400	h-extension	400

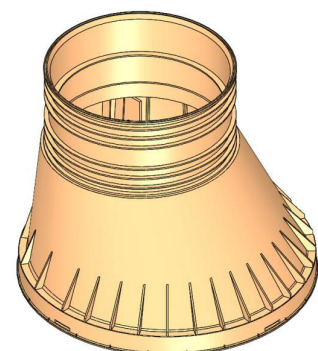

MANHOLE 800.300

ARTICLE	PARTS
Bottom (BT)	1
BASE (BS 800.300)	2
EXTENSION (EXT. 800.500)	3
CONE (CON)	4

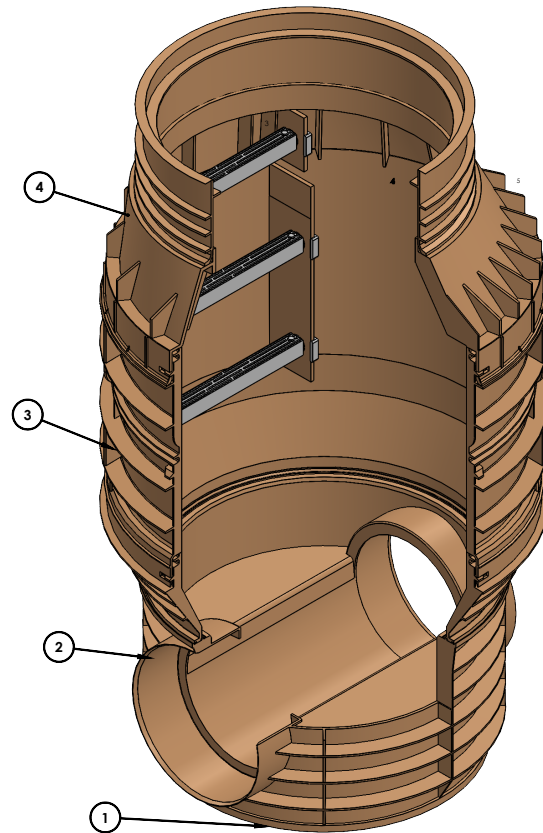
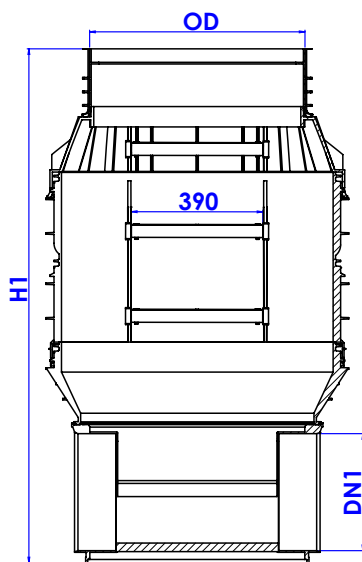

BASE ID800X300

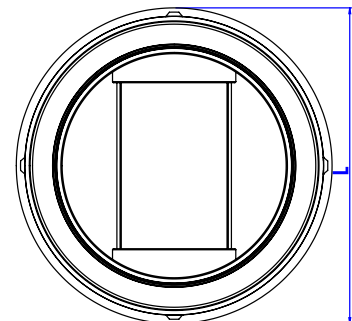
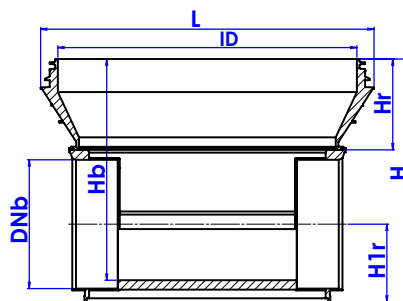
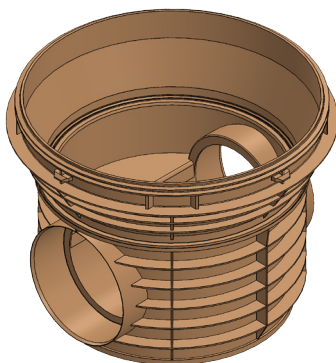

ELEMENT	ID	DNb	H (mm)	Hb (mm)	H1r (mm)	L
BS800.300	800	ID300	650	592	208	892

BASE BS800.300 WITH REDUCTION

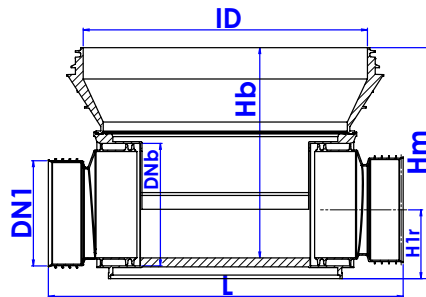
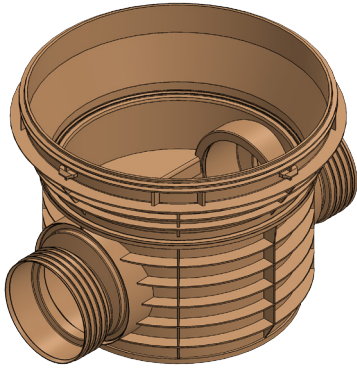

BASE BS 800.300 WITH REDUCTION IDXOD

ELEMENT	ID	DN	DNb	H (mm)	Hb (mm)	H1r (mm)	L
BS800.300.OD315	800	ID300xOD315	ID300	650	592	182	892
BS800.300.OD250	800	ID300xOD250	ID300	650	592	157	1.017
BS800.300.OD200	800	ID300xOD200	ID300	650	592	182	1.035
B 800.300.OD160	800	ID300xOD160	ID300	650	592	157	1.041
BS800.300.OD110	800	ID300xOD110	ID300	650	592	196	1.222
BS800.250.OD250	800	ID250xOD250	ID300	650	592	168	1.007
BS800.250.OD200	800	ID250xOD200	ID300	650	592	146	1.017
BS800.250.OD160	800	ID250xOD160	ID300	650	592	133	1.019
BS800.250.OD110	800	ID250xOD110	ID300	650	592	109	1.109
BS800.200.OD200	800	ID200xOD200	ID300	650	592	146	1.035
BS800.200.OD160	800	ID200xOD160	ID300	650	592	133	1.037
BS800.200.OD110	800	ID200xOD110	ID300	650	592	109	1.128

BASE BS 800.300 WITH REDUCTION IDXID

ELEMENT	ID	DN	DNb	H (mm)	Hb (mm)	H1r (mm)	L
BS800.300.ID250	800	ID300xID250	ID300	650	592	182	892
BS800.300.ID200	800	ID300xID200	ID300	650	592	157	1.017
BS800.300.ID250	800	ID250xID250	ID300	650	592	182	1.035
BS800.300.ID200	800	ID250xID200	ID300	650	592	157	1.041
BS800.300.ID200	800	ID200xID200	ID300	650	592	196	1.222

EXTENSION ID800X250

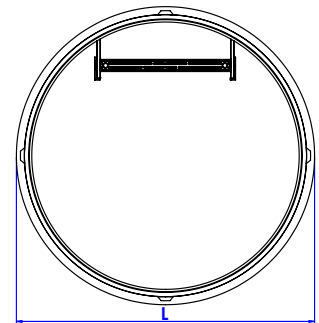
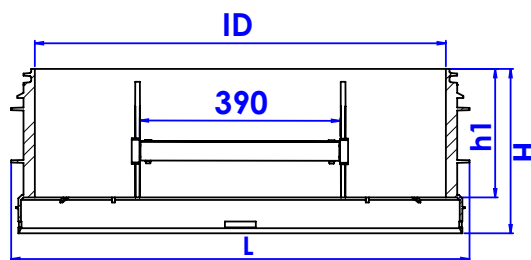
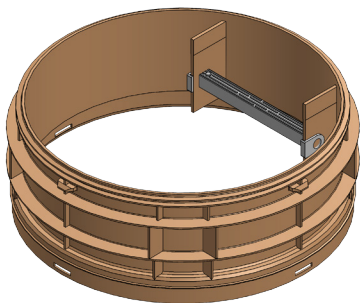

EXTENSION ID800X500

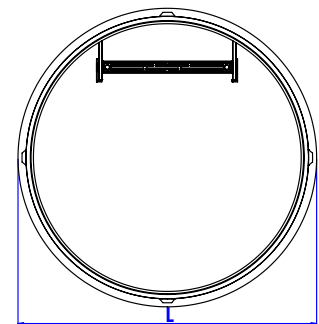
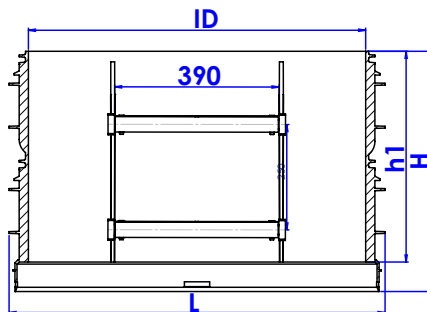
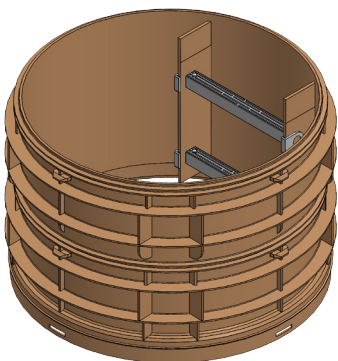

ELEMENT	ID	h1 (mm)	H (mm)	L (mm)
EXT 800.250	800	250	320	892
EXT 800.500	800	500	570	892
EXT 800.750	800	750	820	892
EXT 800.1000	800	1000	1070	892

CONE

CONE 800.600

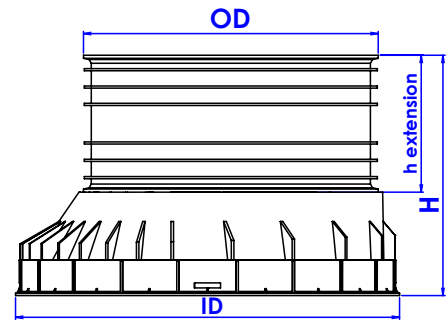
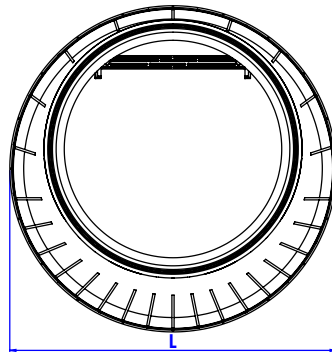
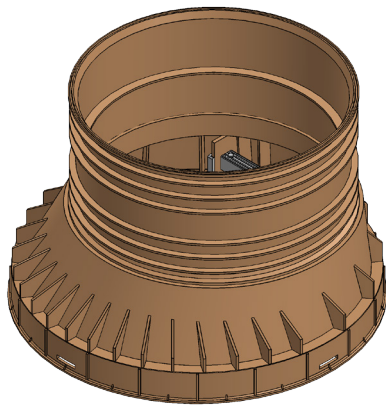

ELEMENT	ID	800
	OD	630
	H	550
CON800.316	h extension	316
CON800.400	h extension	400

MANHOLE 600.300

BASE DN 600 X 300

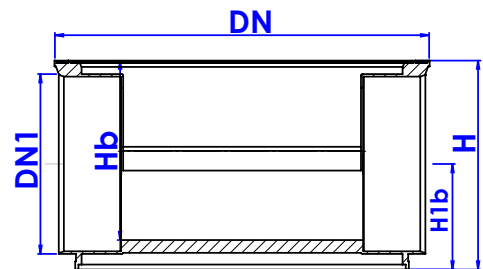
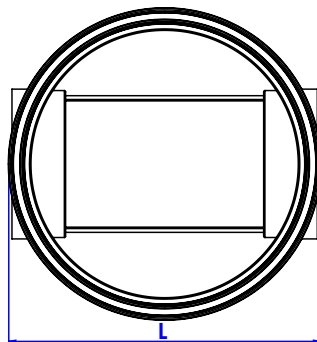
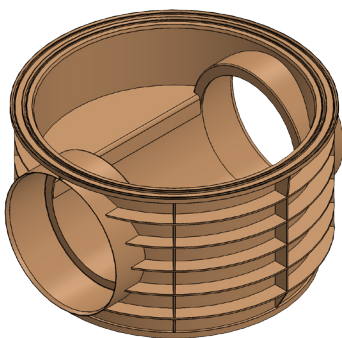

BASE BS600.300

ELEMENT	DN	DNb	H (mm)	Hb (mm)	H1b (mm)	L
BS600.300	ID600/OD630	ID300	354	352	208	723

BASE DN 600 X 300 WITH REDUCTION

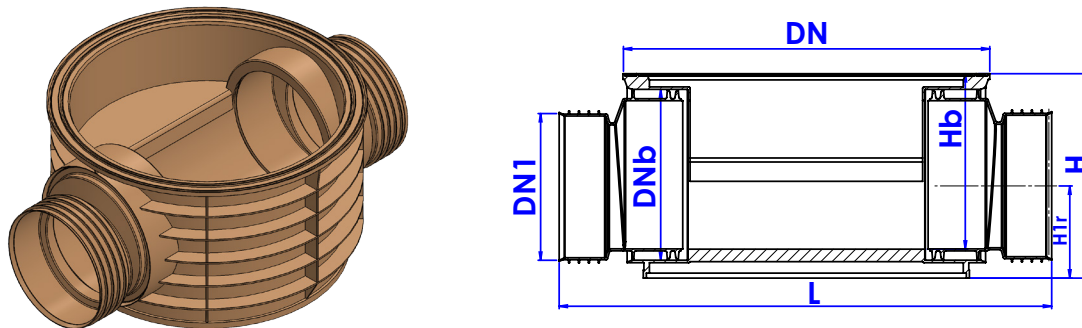

BASE BS600.300 WITH REDUCTION IDXID

ELEMENT	DN	DN1	DNb	H (mm)	Hb (mm)	H1r (mm)	L
BS600.300.ID250	ID600/OD6300	ID300xID250	ID300	650	592	182	857
BS600.300.ID200	ID600/OD6300	ID300xID200	ID300	650	592	157	875
BS600.300.ID250	ID600/OD6300	ID250xID250	ID300	650	592	182	991
BS600.300.ID200	ID600/OD6300	ID250xID200	ID300	650	592	157	1.009
BS600.300.ID200	ID600/OD6300	ID200xID200	ID300	650	592	196	1.028

BASE BS 600.300 WITH REDUCTION IDXOD

ELEMENT	DN	DN1	DNb	H (mm)	Hb (mm)	H1r (mm)	L
BS600.300.OD315	ID600/OD630	ID300xOD315	ID300	650	592	182	743
BS600.300.OD250	ID600/OD630	ID300xOD250	ID300	650	592	157	1.017
BS600.300.OD200	ID600/OD630	ID300xOD200	ID300	650	592	182	1.035
BS600.300.OD160	ID600/OD630	ID300xOD160	ID300	650	592	157	1.041
BS600.300.OD110	ID600/OD630	ID300xOD110	ID300	650	592	196	1.222
BS600.250.OD250	ID600/OD630	ID250xOD250	ID300	650	592	168	1.007
BS600.250.OD200	ID600/OD630	ID250xOD200	ID300	650	592	146	1.017
BS600.250.OD160	ID600/OD630	ID250xOD160	ID300	650	592	133	1.019

BS600.250.OD110	ID600/OD630	ID250xOD110	ID300	650	592	109	1.109
BS600.200.OD200	ID600/OD630	ID200xOD200	ID300	650	592	146	1.035
BS600.200.OD160	ID600/OD630	ID200xOD160	ID300	650	592	133	1.037
BS600.200.OD110	ID600/OD630	ID200xOD110	ID300	650	592	109	1.128

BASE 600.300 WITH CORRUGATED PIPE AS EXTENSION

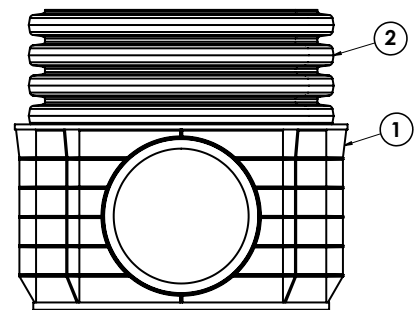
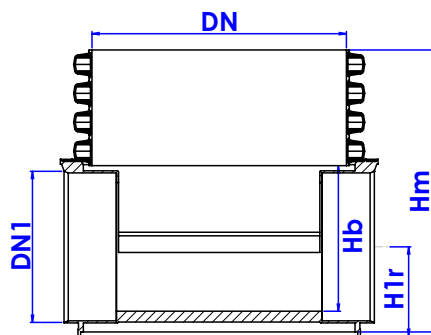
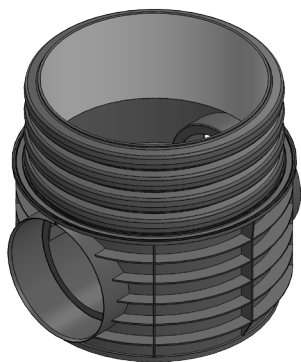

1	BASE 600.300
2	CORRUGATED PIPE DN600

ELEMENT	DN	DNb	H (mm)	Hb (mm)	H1b (mm)	L
BS600.300	ID600/OD630	ID300	up to customer	352	208	723

BASE 600.300 WITH COUPLER AS EXTENSION

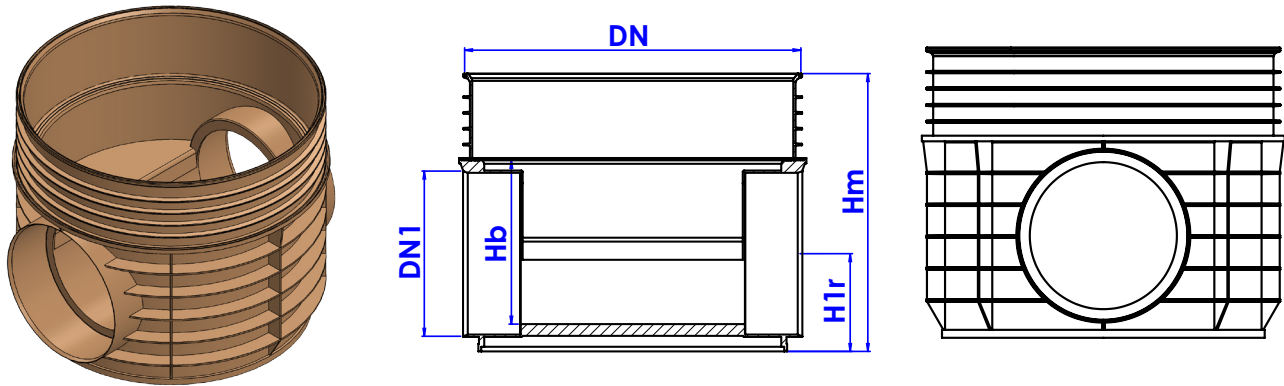

ELEMENT	DN	DNb	H (mm)	Hb (mm)	H1b (mm)	L
BS600.300	ID600/OD630	ID300	592	352	208	723

MANHOLE 400.200/ 400.160

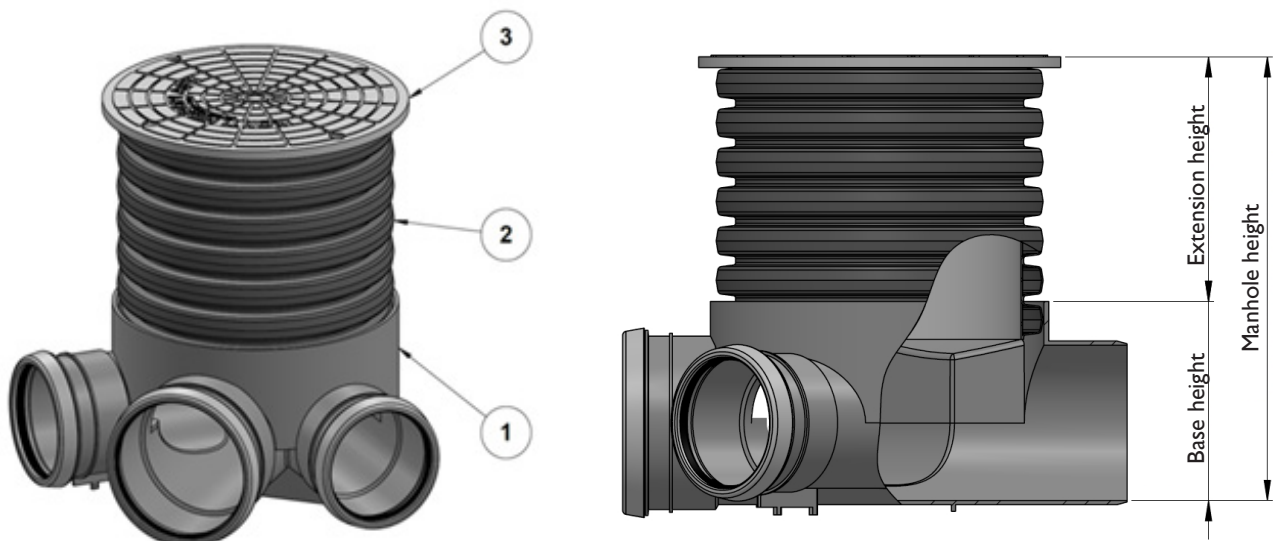

1. Base
2. Extension
3. Cover

BASE 400.200/ 400.160



Adapted for installation of extension with corrugated pipe OD400 in the field. Sealing with rubber gasket.



Adapted for installation of extension with smooth pipe OD400 in the field. Sealing with rubber gasket.

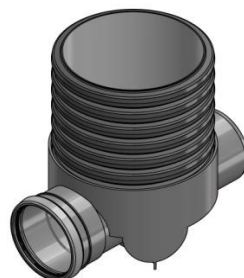

With manufactured extension with corrugated pipe OD400.

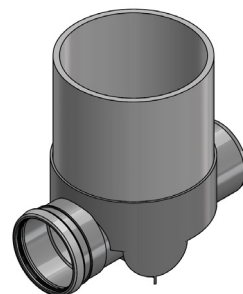

With manufactured extension with PVC pipe.

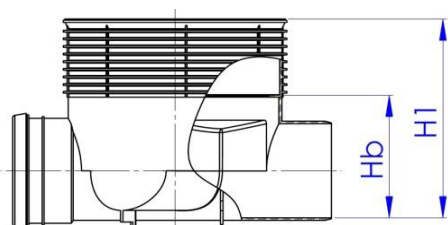
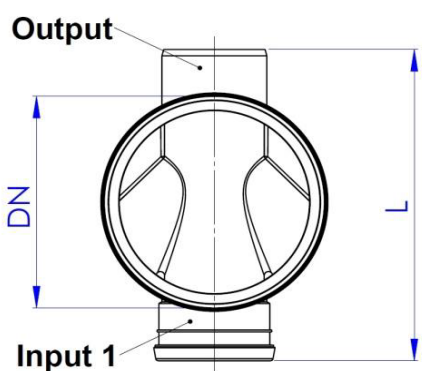
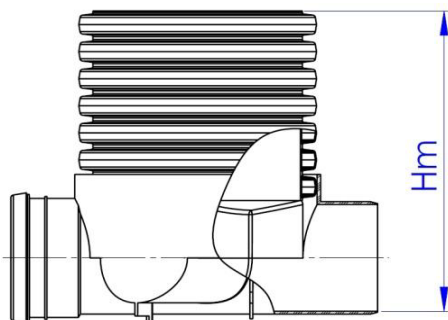

BS 400.200		
DN	OD400	OD400
L	617	617
Hb	247	247
H1	401	401
Hm	According specification	According specification
Output	DN200	DN160
Input 1	DN200	DN160
Input 2	/	/
Input 3	/	/

BASE 400 X 45 LEFT

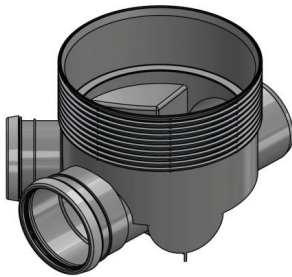

Adapted for installation of extension with corrugated pipe OD400 in the field. Sealing with rubber gasket.

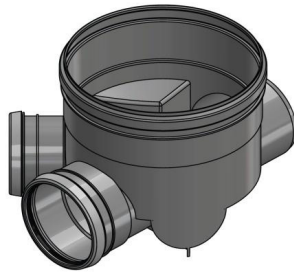

Adapted for installation of extension with smooth pipe OD400 in the field. Sealing with rubber gasket.

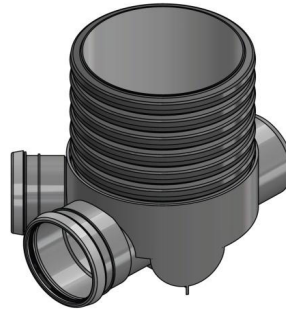

With manufactured extension with corrugated pipe OD400.

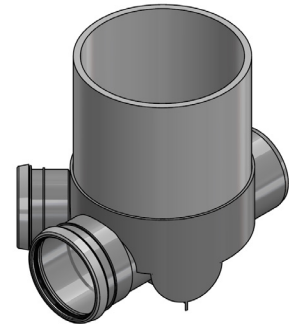

With manufactured extension with PVC pipe.

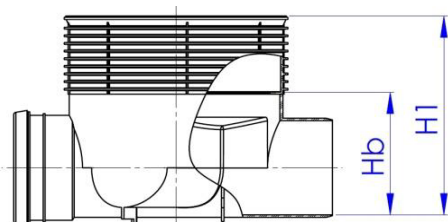
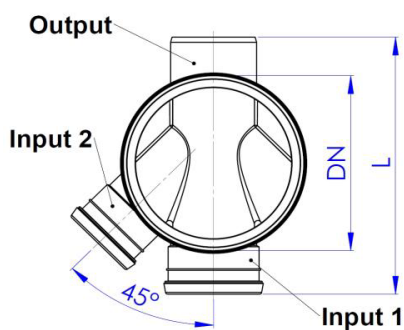
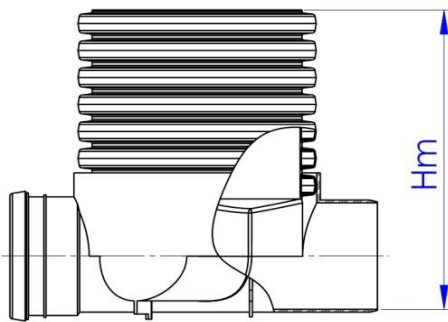

BS 400.160/160 x45" LEVA BS 400.200/160 x45" LEVA		
DN	OD400	OD400
L	617	617
Hb	247	247
H1	401	401
Hm	According specification	According specification
Output	DN200	DN160
Input 1	DN200	DN160
Input 2	DN160	DN160
Input 3	/	/

BASE 400 X 45 RIGHT



Adapted for installation of extension with corrugated pipe OD400 in the field. Sealing with rubber gasket.



Adapted for installation of extension with smooth pipe OD400 in the field. Sealing with rubber gasket.

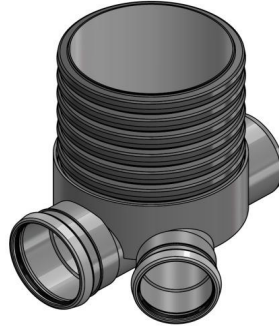

With manufactured extension with corrugated pipe OD400.

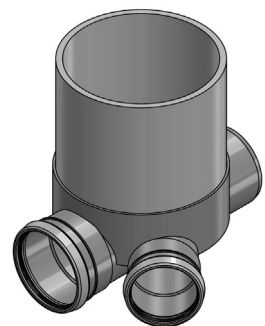

With manufactured extension with PVC pipe.

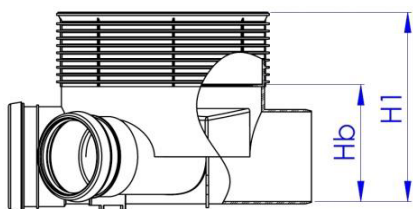
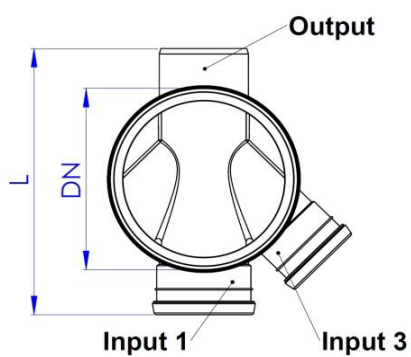
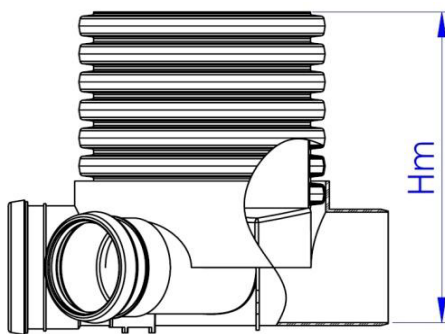

BS 400.160/160 x45" DESNA BS 400.200/160 x45" DESNA		
DN	OD400	OD400
L	617	617
Hb	247	247
H1	401	401
Hm	According specification	According specification
Output	DN200	DN160
Input 1	DN200	DN160
Input 2	/	/
Input 3	DN160	DN160

BA3A 400 2 X 45



Adapted for installation of extension with corrugate pipe OD400 in the field. Sealing with rubber gasket.

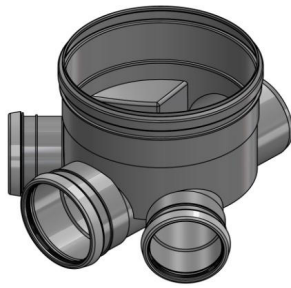

Adapted for installation of extension with smooth pipe OD400 in the field. Sealing with rubber gasket.

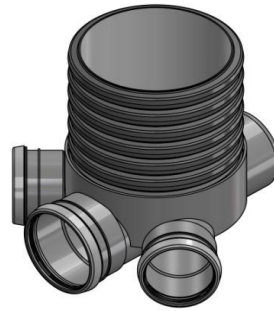

With manufactured extension with corrugated pipe OD400.

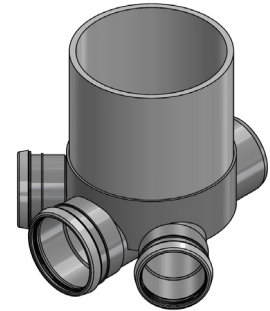

With manufactured extension with PVC pipe.

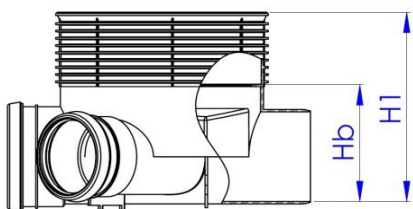
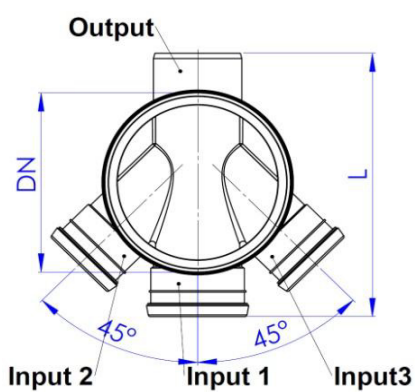
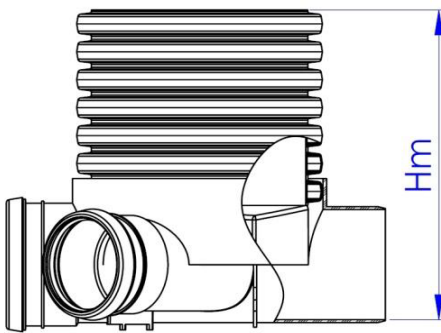

BS 400.160/160 2x45"		
BS 400.200/160 2x45"		
DN	OD400	OD400
L	617	617
Hb	247	247
H1	401	401
Hm	According specification	According specification
Output	DN200	DN160
Input 1	DN200	DN160
Input 2	DN160	DN160
Input 3	DN160	DN160

COVER

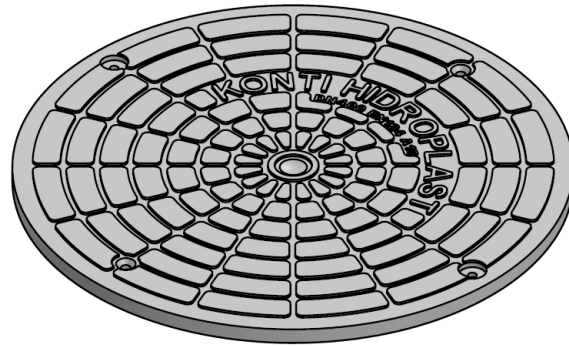
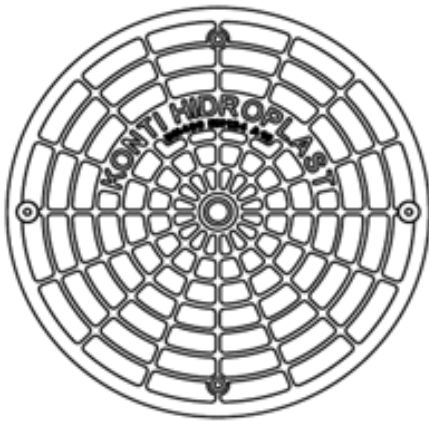
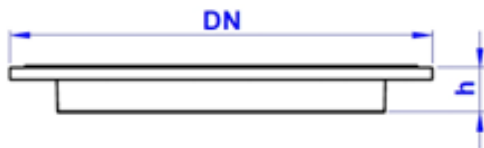

Cover	
DN	400
h	50

RUBBER GASKET-SEALING

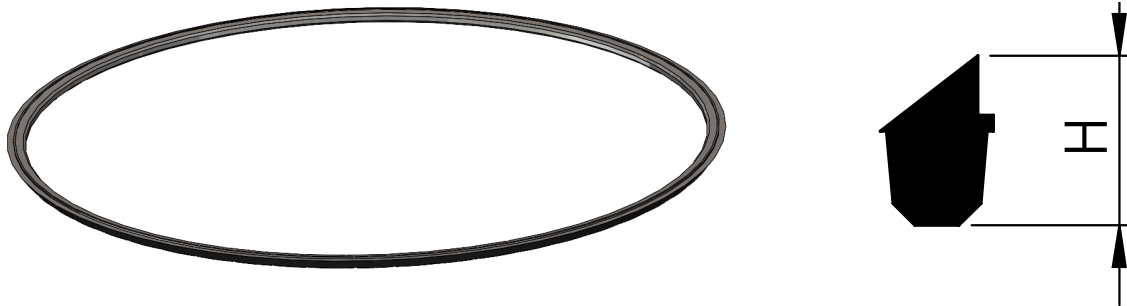

Sealing with rubber gasket between:
Base-Extension, Extension-Extension, Base-Cone, Extension-Cone

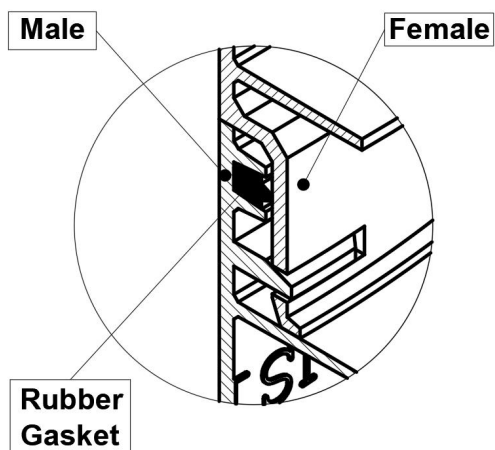

Sealing with rubber gasket

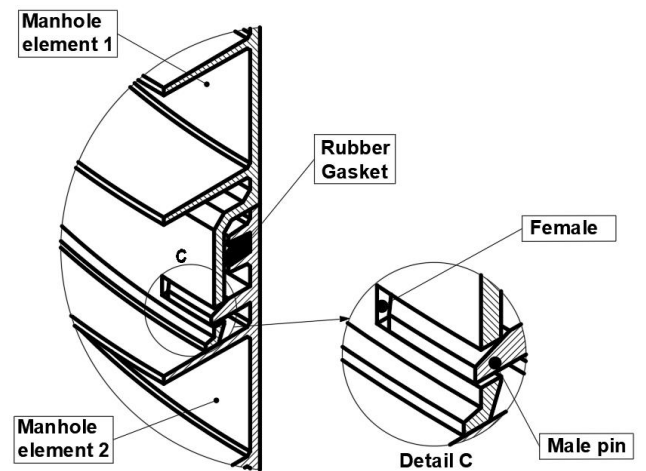

Click clack locking system

Click clack locking system on 4 points between:
Base-Extension, Extension-Extension, Base-Cone, Extension-Cone

THE OTHER SOLUTION REGARDING MANHOLE BOTTOM

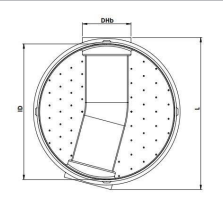
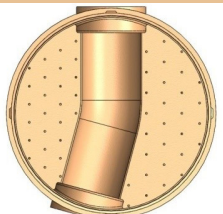
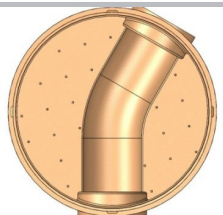
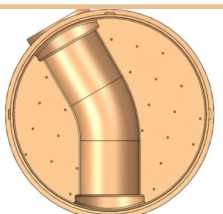
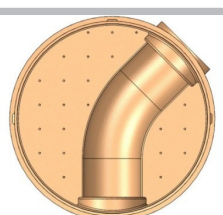
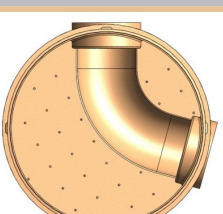
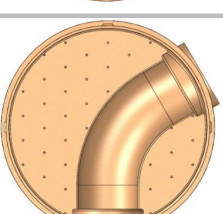
DN In/Outlet	Bend	DHb (mm)	ID (mm)	Hb (mm)	H (mm)	H1b (mm)	L (mm)
	165°	ID300	1000	408	464	206	1086
	195°	ID300	1000	408	464	206	1086
	150°	ID300	1000	408	464	206	1086
	210°						
	135°	ID300	1000	408	464	206	1086
	225°	ID300	1000	408	464	206	1086
	120°	ID300	1000	408	464	206	1086

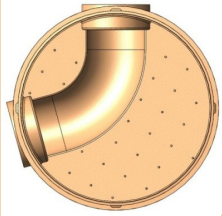
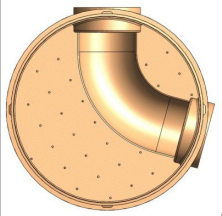
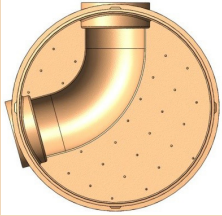
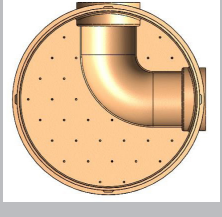
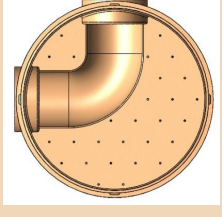
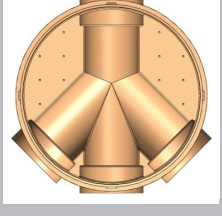
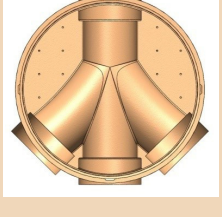
DN In/Outlet	Bend	DHb (mm)	ID (mm)	Hb (mm)	H (mm)	H1b (mm)	L (mm)
	240°	ID300	1000	408	464	206	1086
	105°	ID300	1000	408	464	206	1086
	255°	ID300	1000	408	464	206	1086
	90°	ID300	1000	408	464	206	1086
	270°	ID300	1000	408	464	206	1086
	45°	ID300	1000	408	464	206	1086
	45°	ID300	1000	408	464	206	1086

MANHOLE INSTALATION

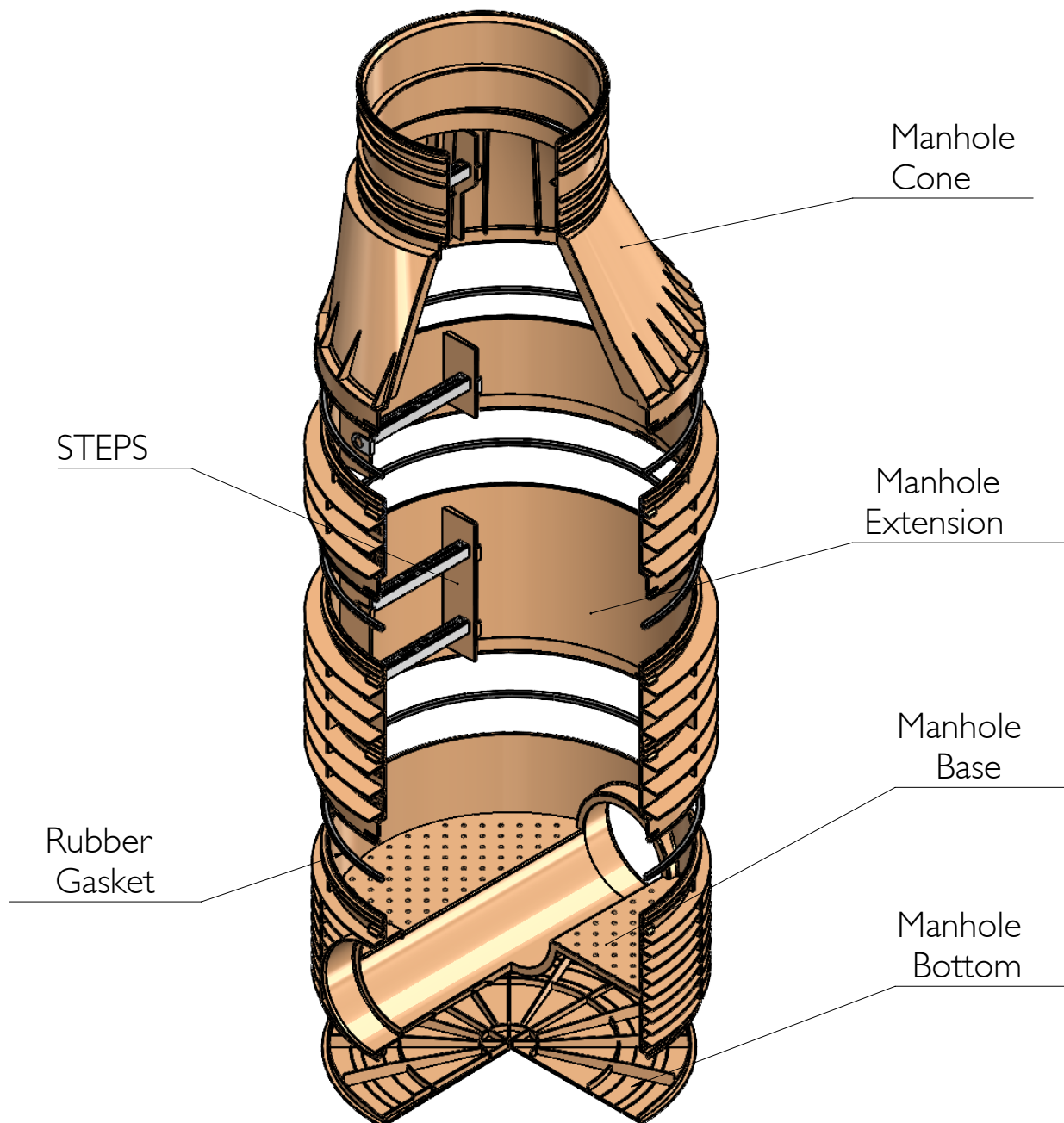

ALL STEPS FOR MANHOLE INSTALLATION



First step is lubrication of edge of the base for rubber installation



Installation of rubber



Installation of first extension.
In the extension stairs are incorporated



Preparation for installation of second extension, lubrication for second rubber and second extension



Lubrication for third rubber and preparation for cone installation



Lubrication and preparation for third rubber installation;
Cone installation



Preparation for side connection with reducer



Side reducer



Pipe connection, inlet of manhole



Manhole with pipe inlet and reduced outlet

1.1 INSTALLATION OF REDUCER TO INJECTION MOLDING BASE ID1000 X ID300

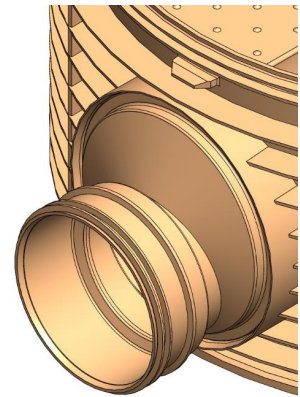

1.2 INSTALLATION OF REDUCER TO INJECTION MOLDING BASE ID1000 X OD315

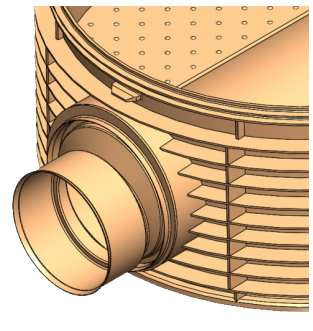
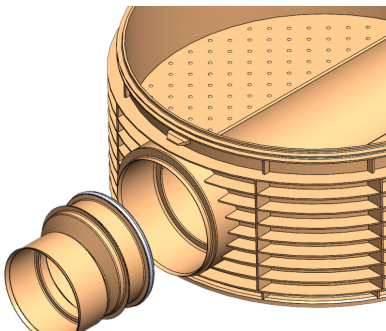
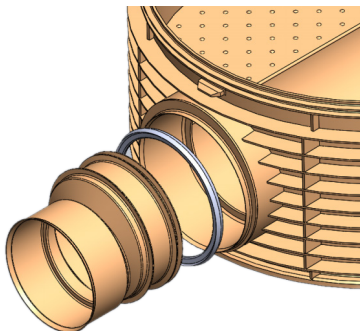

INSTRUCTIONS FOR INSTALLATION OF PP MANHOLE

Like the flexible pipes, the PP manholes need a well compacted bedding and side fill made with fine grain loose soil (coarse sand and fine gravel). (standard EN 1610).

This bedding must be accurately compacted to limit the settlement on the surface surrounding the manhole and compaction can be easily obtained using simple equipment for compaction.

Besides, the use of loose soil for the trench backfill eliminates the risk of road surface expansion and shrinkage due to the water content variation (variation of the groundwater levels) which is the main cause of road surface strain.

The dimensions of the separated material should be from 0 to 32 cm, and dimensions of the crushed material should be from 0 to 16 cm.

The surface should be made in layers of 15 to 20 cm and compacted to 97% by Procter.

You have to use the same material as for the foundation, grained material has to be compacted by layers of 30 cm max, up to 97% of Procter, at least 50 cm wide from the manhole.

Backfill, around and under the manhole is important to prevent possible deformation and leaning.

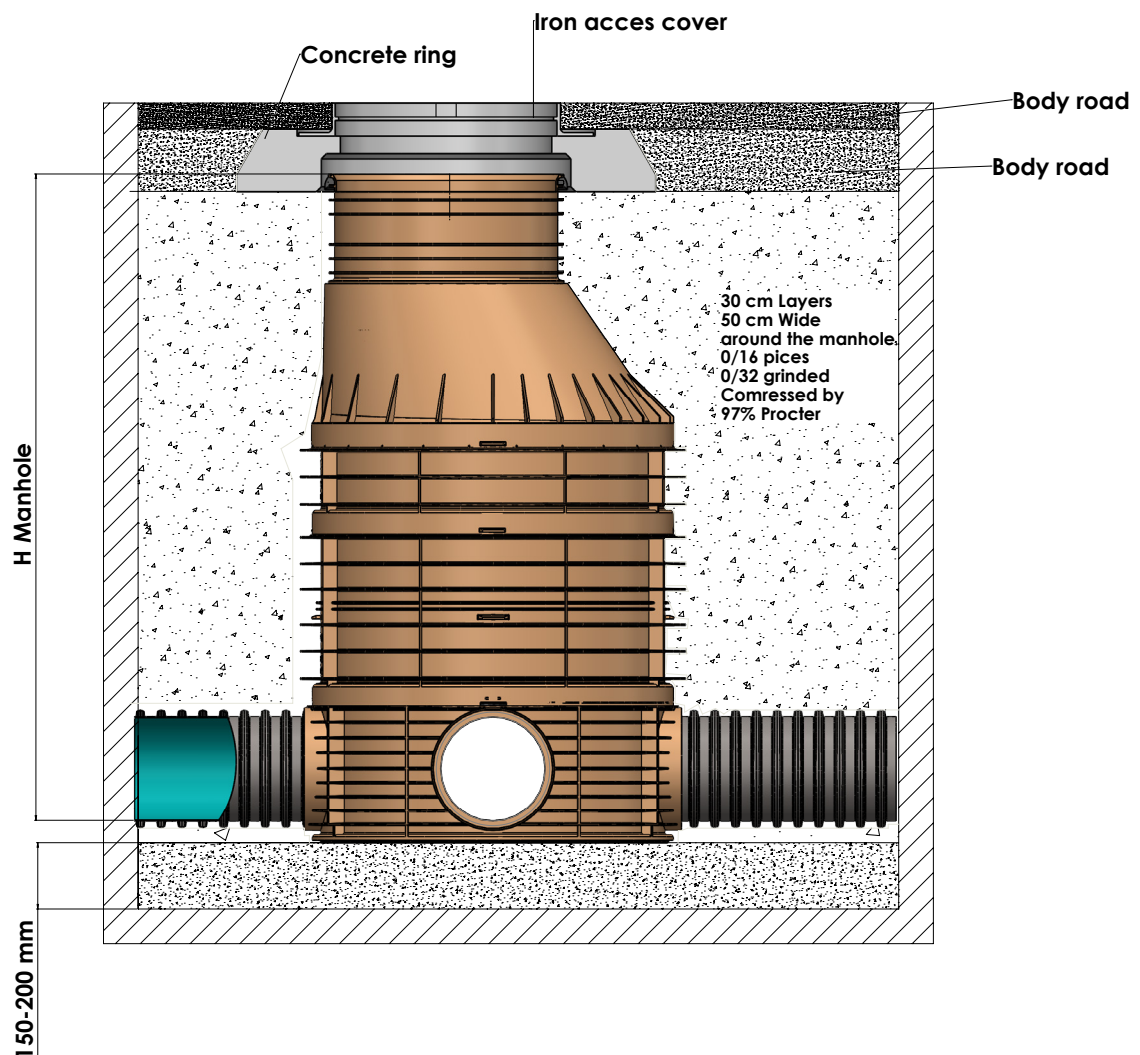

BEDDING AND BACKFILLING

You have to use the same material as for the foundation, grained material has to be compacted by layers of 30 cm max, up to 97% of Procter, at least 50 cm wide from the manhole.

Backfill, around and under the manhole is important to prevent possible deformation and leaning.

INSTALLATION OF PE AND PP MANHOLE IN PRESENCE OF UNDERGROUND WATER

In case of presence of groundwater, the surface should be 30 cm made of concrete MB 15.

Due to low weight the manual installation is possible, in case of machine handling tying the ropes and ribbons is allowed only around the button, bases manhole or to apertures intended for it.

During installation work, excavation should be kept free from water e.g rainwater ,seepage water, spring water or water from leaks from pipelines.

Method of dewatering is shown in the attached document per EN 1610.

Precautions shall be taken to prevent loss of fine material during dewatering.

The influence of dewatering on groundwater movement and stability of the surrounding area shall be taken into account.

On completion of dewatering, any temporary drains will be adequately sealed.

SET UP OF CONCRETE RING

In case of heavy traffic, it is necessary to put a concrete ring on the cone.

This concrete ring must not be in touch with the cone of the manhole.

The empty space above the cone and the concrete ring should be 40mm, and between the cone and the ring a rubber is set up.

The cone should penetrate in the concrete ring 50mm.

In this way the static and dynamic burdening will not be transferred on the body of the manhole but on the pressed sand and the base

around the manhole.

The concrete ring is not necessary in case of installation where there is no traffic and can be used with a direct polyethylene / polypropylene cover or metal cover B 125.

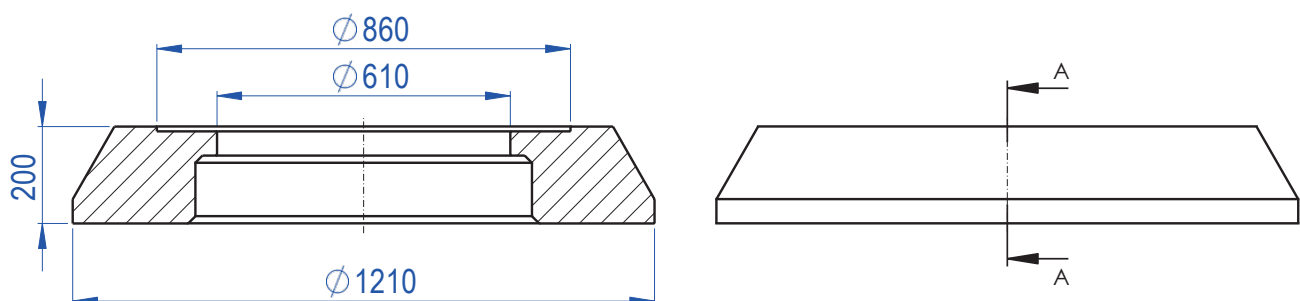

STORAGE AND TRANSPORT INSTRUCTIONS

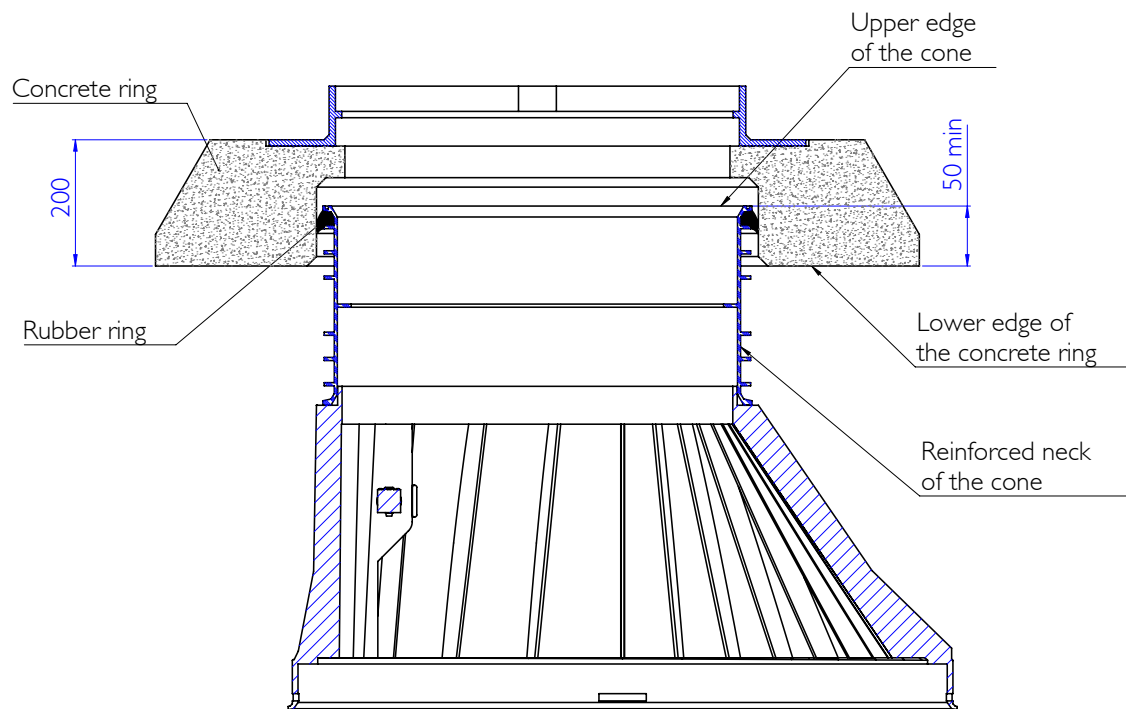

- 1 - During storage and transport of manhole components storing over sharp and spiny objects is not allowed therefore avoid point overloading.
- 2 - While unloading manholes from trucks to the forklifts should be used assisted by straps, without throwing it from height.
- 3 - While moving, pulling over sharp edges or sharp objects should be avoided.
- 4 - Storage height depends on the geometry of the components, but heights above 2.5 m are not recommended.
- 5 - The products can be stored outdoors because they have UV protection.
*If storage period is longer than 2 years, protection from direct sunlight is needed.
- 6 - Freezing is not an issue for components of manholes because PP material is stable up to - 35°C. Although elasticity of rubber
- 7 - Products should be kept out of contact with organic solvents and direct flame exposure.
- 8 - Module components are delivered together.
- 9 - Every component of the manhole has its ID number.

STANDARDS

- EN 13598-1 Plastic pressurless pipe system, underground drainage and sewer: PVC-U, PP and PE. Specification for manholes of accessories including shallow inspection
- EN 13598-2 Plastic pressurless pipe system, underground drainage and sewer: PVC-U, PP and PE. Specification for manholes and inspection chambers in a traffic environment
- EN 476 Common requests for components used in.
- ISO 13268 Determination of the class of stiffness.
- ISO 13266 Determination of the resistance in case of traffic or other external burdens.
- DIN 4124 Excavation, trenches, width of working space.
- EN 1610 Construction and testing of drainage and sewer



SYSTEM CERTIFIED

ISO 9001:2015
ISO 45001:2018
ISO 14001:2015

No.01442/0
No.00590/0
No.00211/0





**KONTI
HIDROPLAST®**



NORTH MACEDONIA
1480 Gevgelija, Industriska bb



+389 34 212 064 +389 34 215 225
+389 34 211 757 +389 34 215 226



+389 34 211 964



contact@konti-hidroplast.com.mk
hidroplast@t-home.mk



www.konti-hidroplast.com.mk



qualityaustria
SYSTEM CERTIFIED
ISO 9001:2008 No. 01442/0
ISO 14001:2004 No. 00211/0

EXACT IGH



MDC

MARCH, 2024

