

Излиено колено Injection molding Elbow			
PPHM "ID"			
Колено Elbow	Димензии Dimensions		
	D (mm)	D1 (mm)	β (°)
ID300	342,5	342,5	45
ID250	285	285	45
ID200	232	232	45
ID300	342,5	342,5	90
ID250	285	285	90
ID200	232	232	90

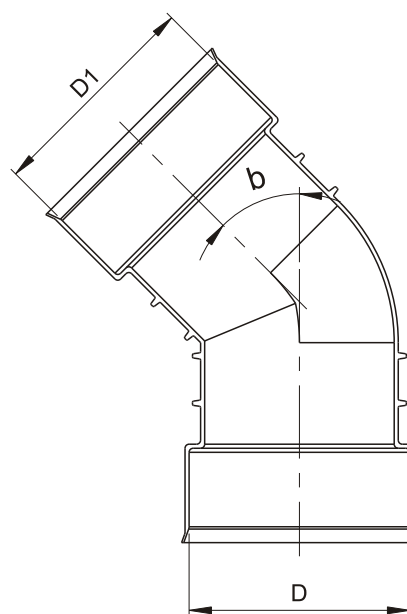

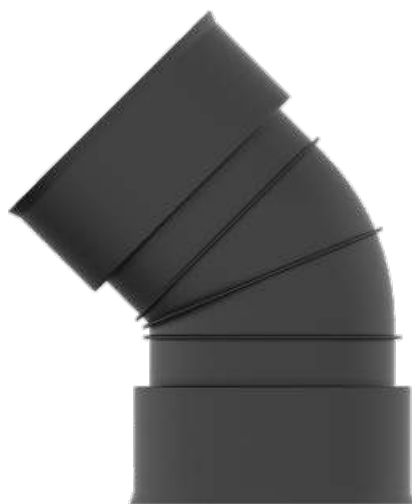

Излиен Тештек Injection molding TEE				
PPHM "ID"				
Тештек TEE	Димензии Dimensions			
	D	D1	L	L1
	(mm)	(mm)	(mm)	(mm)
ID200	232	232	500	260
ID250	285	285	535	272
ID300	342,5	342,5	690	355

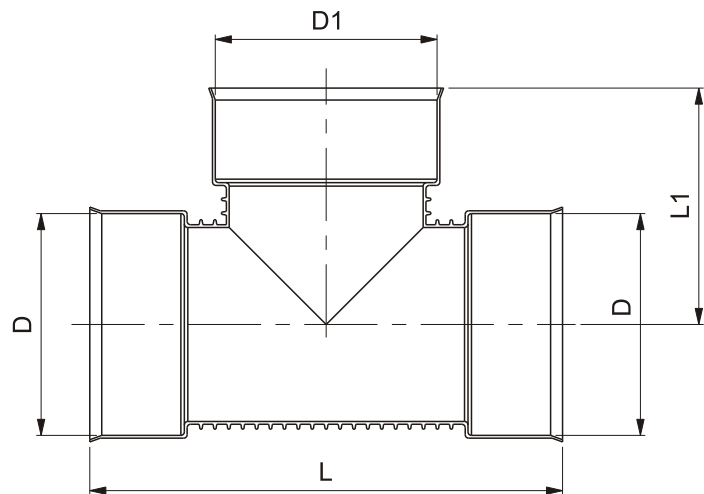
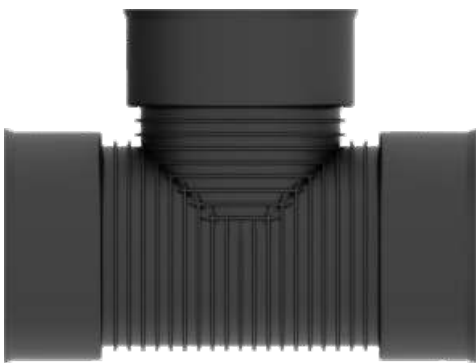



Излиена Коса Рачва Injection molding Y-branch				
PPHM "ID"				
Коса Рачва Y-branch	Димензии Dimensions			
	D	D1	L	L1
	(mm)	(mm)	(mm)	(mm)
ID200	232	232	585	415
ID250	285	285	665	470
ID300	342,5	342,5	815	600

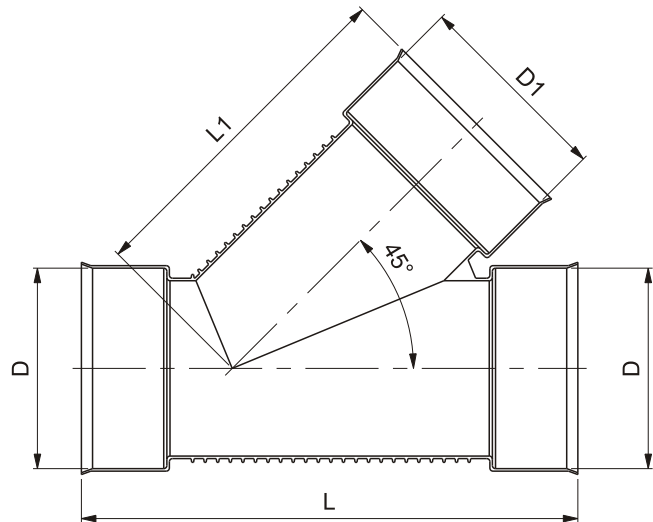
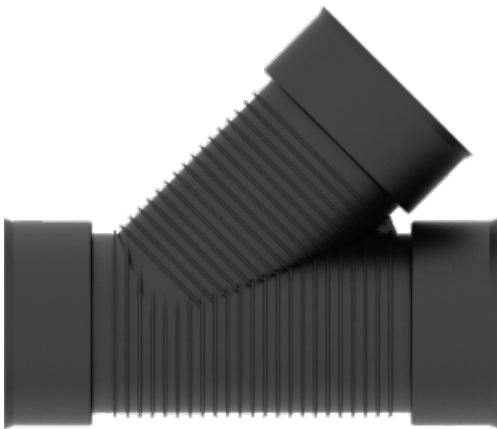



Излиена Коса Рачва Редуцир Injection molding Y-branch Reducer				
PPHM "ID"				
Коса Рачва Редуцир Y-branch Reducer	Димензии Dimensions			
	D (mm)	D1 (mm)	L (mm)	L1 (mm)
ID300 x ID250	342,5	285	815	725
ID300 x ID200	342,5	232	815	688
ID250 x ID200	285	232	665	590

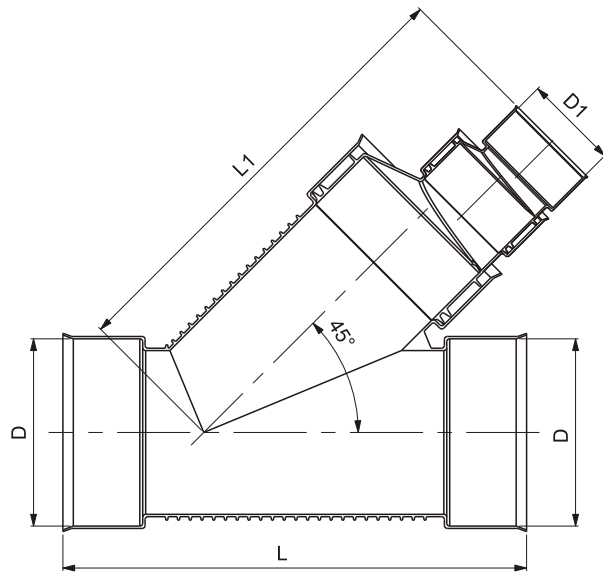
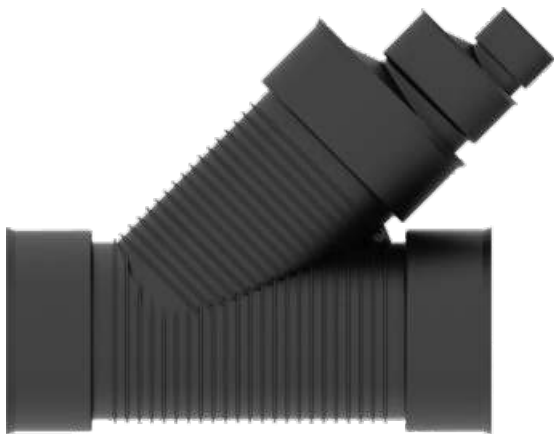



Излиен ТЕЕ Редуцир Injection molding TEE Reducer				
PPHM "ID"				
ТЕЕ РТЕЕ Редуцир TEE Reducer	Димензии Dimensions			
	D (mm)	D1 (mm)	L (mm)	L1 (mm)
ID300 x ID250	342,5	285	690	480
ID300 x ID200	342,5	232	690	444
ID250 x ID200	285	232	535	390

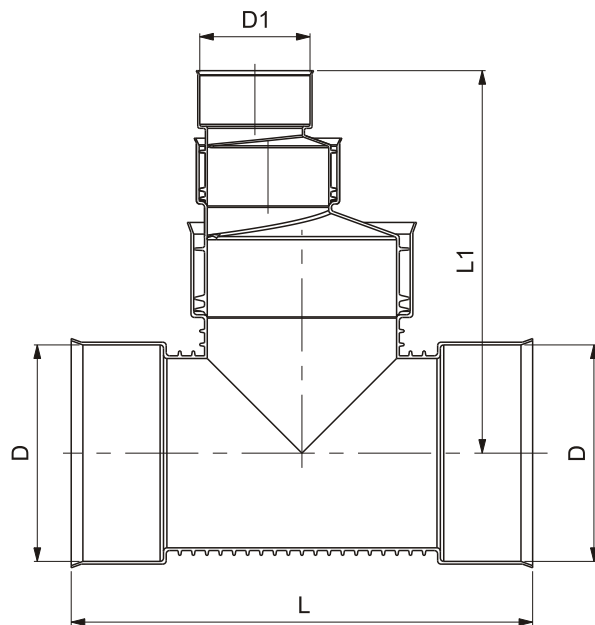
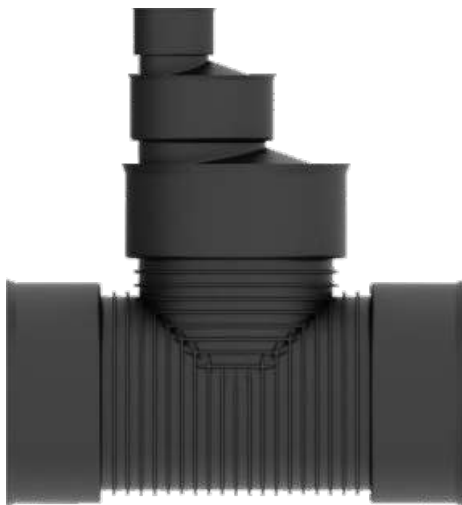



Излиен Редуцир Injection molding Reducer			
PPHM "ID"			
Редуцир Reducer	Димензии Dimensions		
	D	D1	L
	(mm)	(mm)	(mm)
ID300 x ID250	342,5	285	375
ID300 x ID200	342,5	232	339
ID250 x ID200	285	232	313

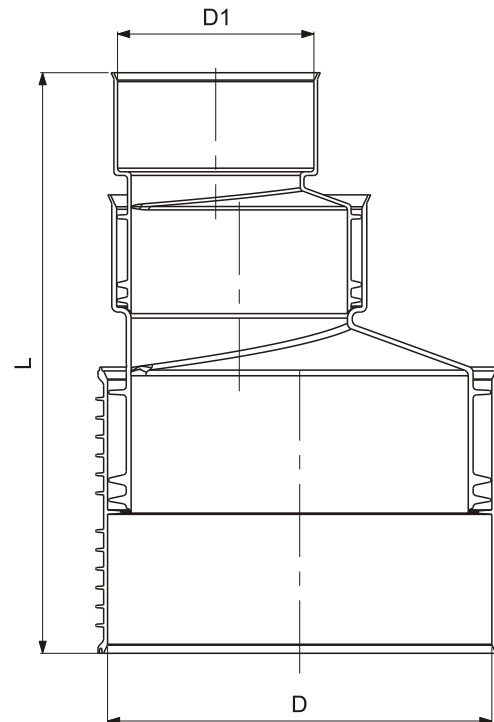

Заварено колено Welded elbow			
PPHM "ID"			
Колено Elbow	Димензии Dimensions		
	OD (mm)	ID (mm)	β (°)
ID200	230	200	11
ID250	284	250	11
ID300	342	300	11
ID400	455	400	11
ID500	568	500	11
ID600	682	600	11
ID800	905	800	11
ID1000	1130	1000	11
ID1200	1350	1200	11

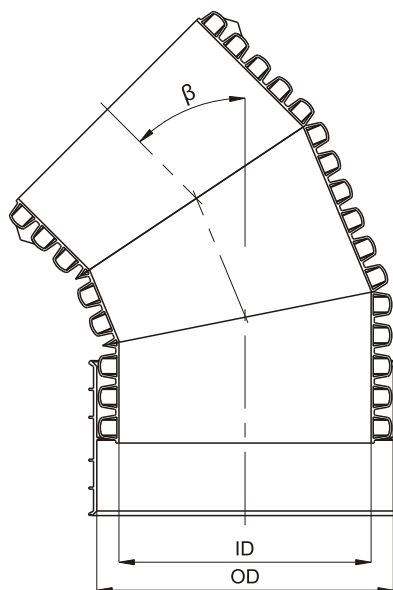

Заварено колено Welded elbow			
PPHM "ID"			
Колено Elbow	Димензии Dimensions		
	OD (mm)	ID (mm)	β (°)
ID200	230	200	22
ID250	284	250	22
ID300	342	300	22
ID400	455	400	22
ID500	568	500	22
ID600	682	600	22
ID800	905	800	22
ID1000	1130	1000	22
ID1200	1350	1200	22

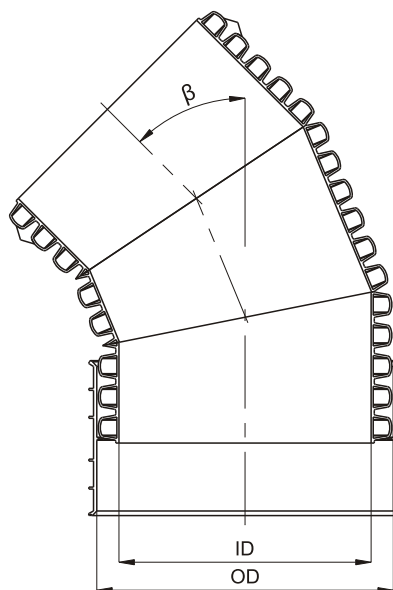

Заварено колено Welded elbow			
PPHM "ID"			
Колено Elbow	Димензии Dimensions		
	OD (mm)	ID (mm)	β (°)
ID200	230	200	30
ID250	284	250	30
ID300	342	300	30
ID400	455	400	30
ID500	568	500	30
ID600	682	600	30
ID800	905	800	30
ID1000	1130	1000	30
ID1200	1350	1200	30

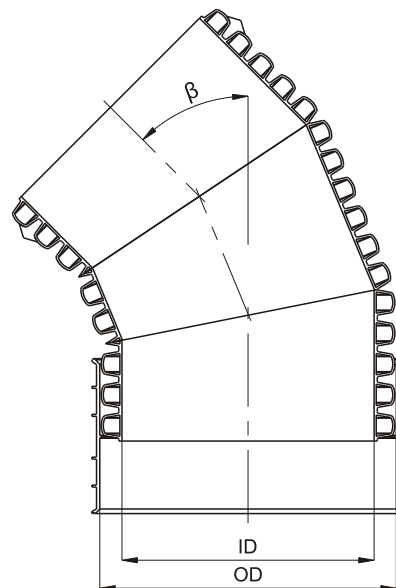

Заварено колено Welded elbow			
PPHM "ID"			
Колено Elbow	Димензии Dimensions		
	OD (mm)	ID (mm)	β (°)
ID400	455	400	45
ID500	568	500	45
ID600	682	600	45
ID800	905	800	45
ID1000	1130	1000	45
ID1200	1350	1200	45

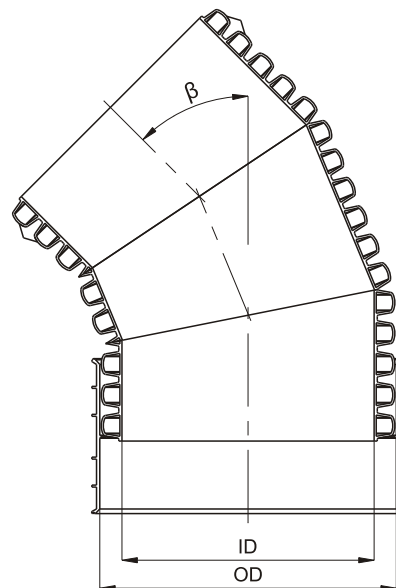

Заварено колено Welded elbow			
PPHM "ID"			
Колено Elbow	Димензии Dimensions		
	OD (mm)	ID (mm)	β (°)
ID200	230	200	60
ID250	284	250	60
ID300	342	300	60
ID400	455	400	60
ID500	568	500	60
ID600	682	600	60
ID800	905	800	60
ID1000	1130	1000	60
ID1200	1350	1200	60

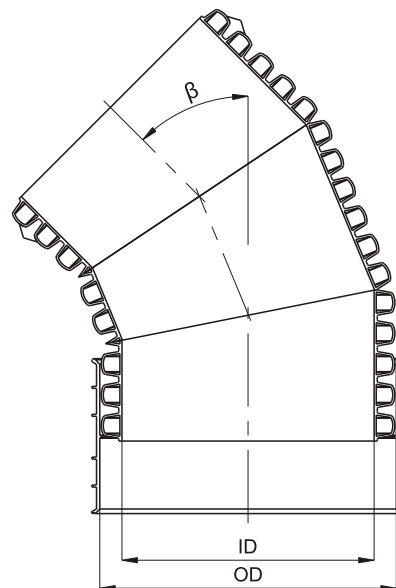

Заварено колено Welded elbow			
PPHM "ID"			
Колено Elbow	Димензии Dimensions		
	OD (mm)	ID (mm)	β (°)
ID400	455	400	90
ID500	568	500	90
ID600	682	600	90
ID800	905	800	90
ID1000	1130	1000	90
ID1200	1350	1200	90

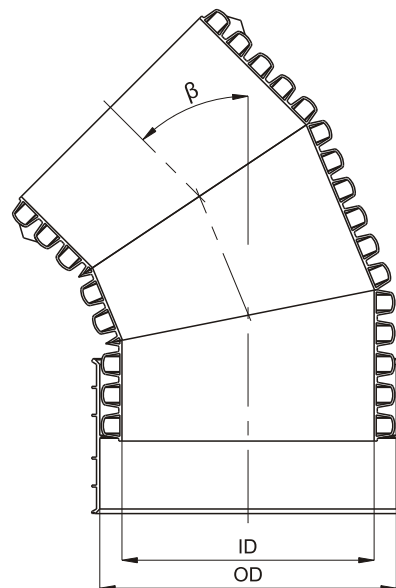
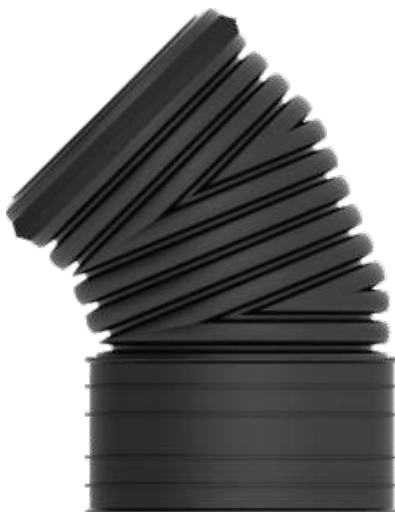



Заварен Тештек Welded TEE				
PPHM "ID"				
Тештек TEE	Димензии Dimensions			
	OD (mm)	ID (mm)	L (mm)	L1 (mm)
ID250	284	250	803	401
ID400	455	400	1106	553
ID500	568	500	1234	589
ID600	682	600	1346	639
ID800	905	800	1616	592
ID1000	1130	1000	1884	691
ID1200	1350	1200	2111	829

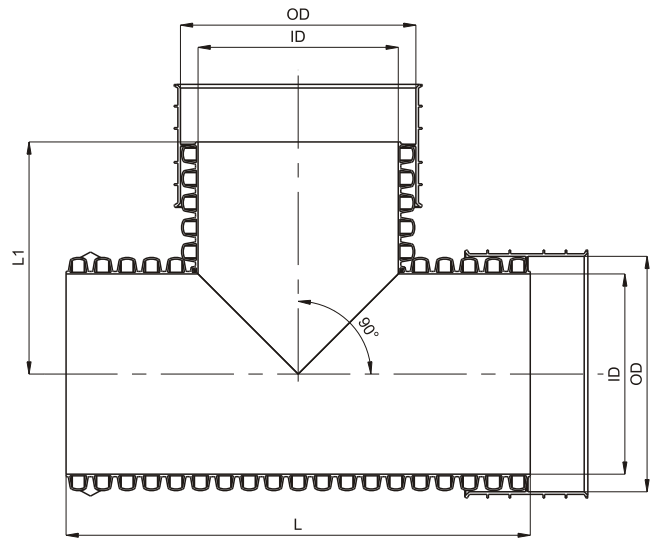

Заварена Коса рачва Welded Y-branch				
PPHM "ID"				
Коса рачва Y-branch	Димензии Dimensions			
	OD (mm)	ID (mm)	L (mm)	L1 (mm)
ID400	455	400	1299	866
ID500	568	500	1459	1066
ID600	682	600	1683	1211
ID800	905	800	2046	1400
ID1000	1130	1000	2386	1633
ID1200	1350	1200	2865	1960

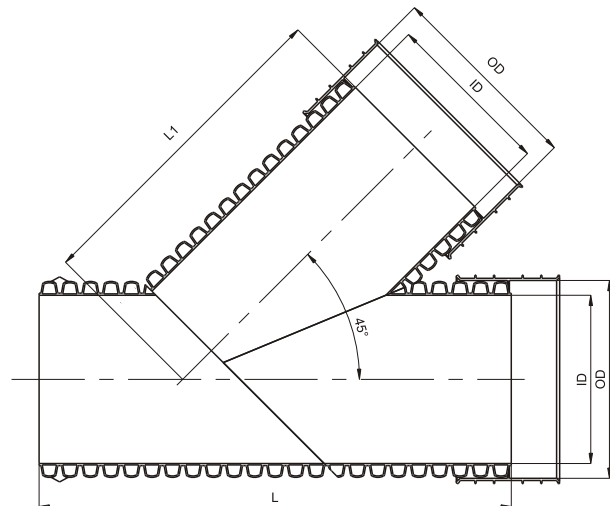
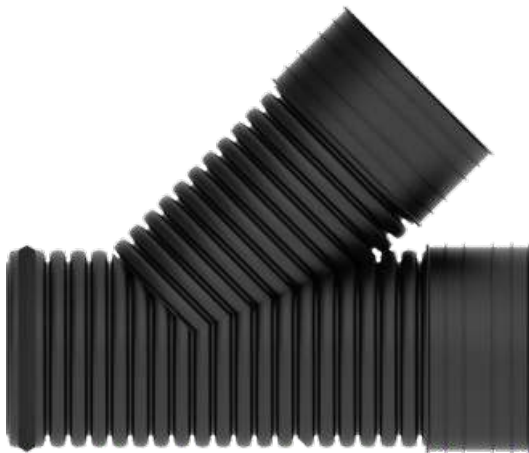



Заварен Тештек Редуцир / Welded TEE Reducer						
PPHM "ID"						
TEE Редуцир TEE Reducer	Димензии Dimensions					
	OD	ID	OD1	ID1	L	L1
	(mm)	(mm)	(mm)	(mm)	(mm)	(mm)
ID300XID200	342	300	230	200	607	317
ID400XID200	455	400	230	200	673	374
ID400XID250	455	400	284	250	722	381
ID400XID300	455	400	342	300	770	412
ID500XID200	568	500	230	200	729	430
ID500XID250	568	500	284	250	785	438
ID500XID300	568	500	342	300	842	469
ID500XID400	568	500	455	400	954	526
ID600XID200	682	600	230	200	740	487
ID600XID250	682	600	284	250	740	495
ID600XID300	682	600	342	300	808	526
ID600XID400	682	600	455	400	942	583
ID600XID500	682	600	568	500	1077	615

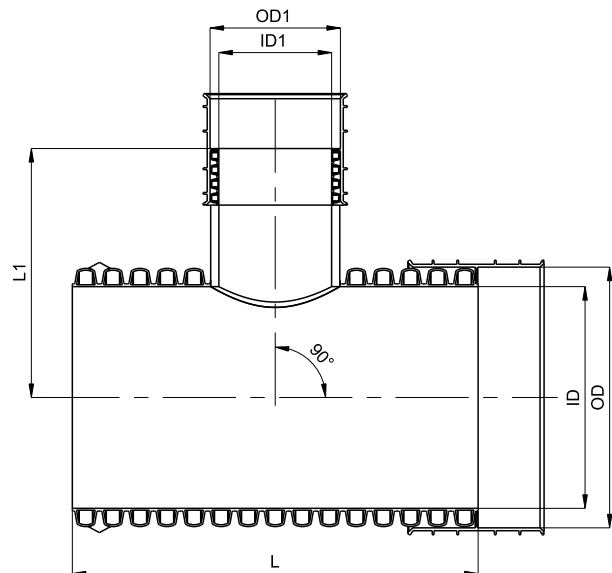



Заварен Тештек Редуцир / Welded TEE Reducer						
PPHM "ID"						
TEE Редуцир TEE Reducer	Димензии Dimensions					
	OD	ID	OD1	ID1	L	L1
	(mm)	(mm)	(mm)	(mm)	(mm)	(mm)
ID800XID200	905	800	230	200	754	599
ID800XID250	905	800	284	250	754	606
ID800XID300	905	800	342	300	862	637
ID800XID400	905	800	455	400	969	695
ID800XID500	905	800	568	500	1077	727
ID800XID600	905	800	682	600	1508	854
ID1000XID200	1130	1000	230	200	754	711
ID1000XID250	1130	1000	284	250	754	719
ID1000XID300	1130	1000	342	300	879	750
ID1000XID400	1130	1000	455	400	1005	807
ID1000XID500	1130	1000	568	500	1130	839
ID1000XID600	1130	1000	682	600	1507	967
ID1200XID200	1350	1200	230	200	905	821
ID1200XID250	1350	1200	284	250	905	829
ID1200XID300	1350	1200	342	300	905	860
ID1200XID400	1350	1200	455	400	1056	917
ID1200XID500	1350	1200	568	500	1206	949
ID1200XID600	1350	1200	682	600	1659	1279

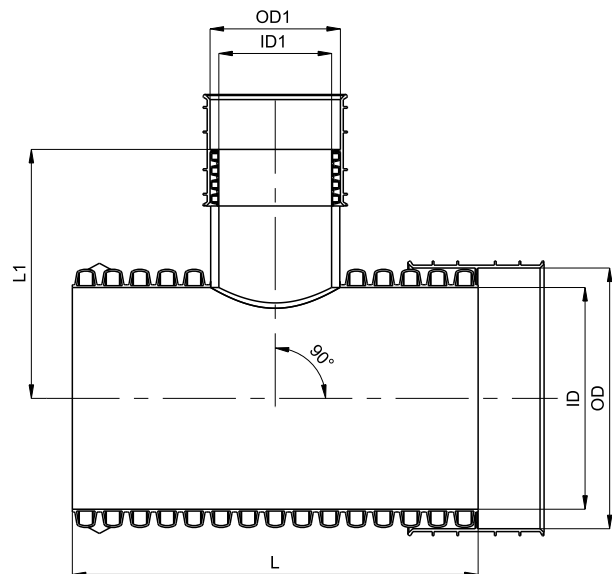



Заварена Коса Рачва Редуцир / Welded Y-branch Reducer						
PPHM "ID"						
Коса Рачва Редуцир Y-branch Reducer	Димензии Dimensions					
	OD	ID	OD1	ID1	L	L1
	(mm)	(mm)	(mm)	(mm)	(mm)	(mm)
ID300XID200	342	300	230	200	876	603
ID400XID200	455	400	230	200	962	683
ID400XID250	455	400	284	250	1058	717
ID400XID300	455	400	342	300	1106	778
ID500XID200	568	500	230	200	1010	763
ID500XID250	568	500	284	250	1066	797
ID500XID300	568	500	342	300	1178	857
ID500XID400	568	500	455	400	1346	972
ID600XID200	682	600	230	200	1010	844
ID600XID250	682	600	284	250	1077	878
ID600XID300	682	600	342	300	1144	938
ID600XID400	682	600	455	400	1346	1052
ID600XID500	682	600	568	500	1481	1141

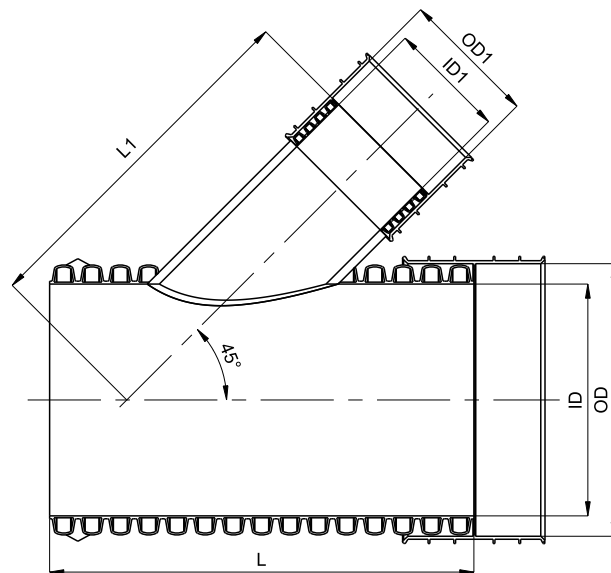



Заварена Коса Рачва Редуцир / Welded Y-branch Reducer						
PPHM "ID"						
Коса Рачва Редуцир Y-branch Reducer	Димензии Dimensions					
	OD	ID	OD1	ID1	L	L1
	(mm)	(mm)	(mm)	(mm)	(mm)	(mm)
ID800XID200	905	800	230	200	969	1001
ID800XID250	905	800	284	250	1077	1036
ID800XID300	905	800	342	300	1185	1096
ID800XID400	905	800	455	400	1292	1210
ID800XID500	905	800	568	500	1508	1298
ID800XID600	905	800	682	600	1616	1333
ID1000XID200	1130	1000	230	200	1005	1160
ID1000XID250	1130	1000	284	250	1130	1195
ID1000XID300	1130	1000	342	300	1256	1255
ID1000XID400	1130	1000	455	400	1382	1369
ID1000XID500	1130	1000	568	500	1507	1457
ID1000XID600	1130	1000	682	600	1633	1492
ID1200XID200	1350	1200	230	200	1206	1316
ID1200XID250	1350	1200	284	250	1206	1350
ID1200XID300	1350	1200	342	300	1357	1410
ID1200XID400	1350	1200	455	400	1508	1524
ID1200XID500	1350	1200	568	500	1659	1613
ID1200XID600	1350	1200	682	600	1810	1647

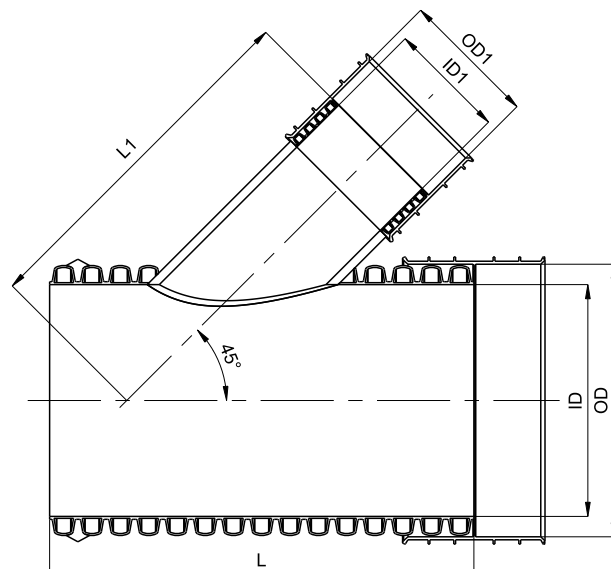



Заварен Редуцир / Welded Reducer					
PPHM "ID"					
Редуцир Reducer	Димензии Dimensions				
	OD	ID	OD1	ID1	L
	(mm)	(mm)	(mm)	(mm)	(mm)
ID300XID200	342	300	230	200	131
ID400XID200	455	400	230	200	131
ID400XID250	455	400	284	250	140
ID400XID300	455	400	342	300	179
ID500XID200	568	500	230	200	131
ID500XID250	568	500	284	250	140
ID500XID300	568	500	342	300	179
ID500XID400	568	500	455	400	251
ID600XID200	682	600	230	200	131
ID600XID250	682	600	284	250	140
ID600XID300	682	600	342	300	179
ID600XID400	682	600	455	400	251
ID600XID500	682	600	568	500	291

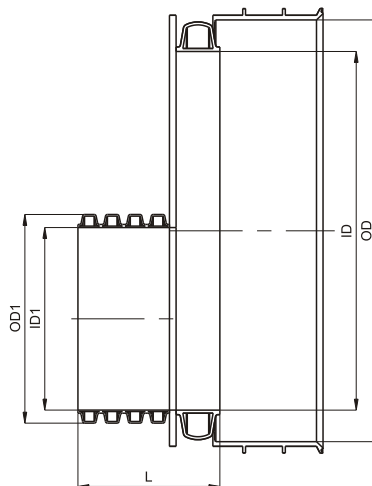

Заварен Редуцир / Welded Reducer					
PPHM "ID"					
Редуцир Reducer	Димензии Dimensions				
	OD (mm)	ID (mm)	OD1 (mm)	ID1 (mm)	L (mm)
ID800XID200	905	800	230	200	131
ID800XID250	905	800	284	250	140
ID800XID300	905	800	342	300	179
ID800XID400	905	800	455	400	251
ID800XID500	905	800	568	500	291
ID800XID600	905	800	682	600	279
ID1000XID200	1130	1000	230	200	131
ID1000XID250	1130	1000	284	250	140
ID1000XID300	1130	1000	342	300	179
ID1000XID400	1130	1000	455	400	251
ID1000XID500	1130	1000	568	500	291
ID1000XID600	1130	1000	682	600	279
ID1000XID800	1130	1000	905	800	333
ID1200XID200	1350	1200	230	200	131
ID1200XID250	1350	1200	284	250	140
ID1200XID300	1350	1200	342	300	179
ID1200XID400	1350	1200	455	400	251
ID1200XID500	1350	1200	568	500	291
ID1200XID600	1350	1200	682	600	279
ID1200XID800	1350	1200	905	800	333
ID1200XID1000	1350	1200	1130	1000	387

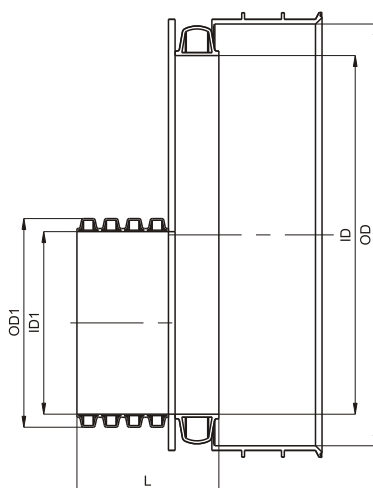



Заварена Завршна тапа Welded End cap			
PPHM "ID"			
Завршна тапа End cap	Димензии Dimensions		
	OD (mm)	ID (mm)	L (mm)
ID200	230	200	113
ID250	284	250	118
ID300	342	300	145
ID400	455	400	180
ID500	568	500	195
ID600	682	600	198
ID800	905	800	300
ID1000	1130	1000	385
ID1200	1350	1200	460

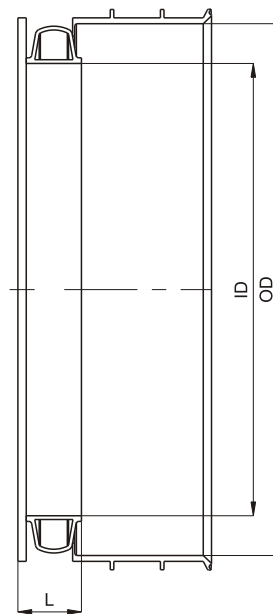



Муф Socket			
PPHM "ID"			
Муф Socket	Димензии Dimensions		
	OD	ID	L
	(mm)	(mm)	(mm)
ID 100	250	119,7	130,7
ID 200	180	232,3	251,3
ID 250	195	284,8	304,8
ID 300	250	342,4	363,4
ID 400	320	455,5	487,5
ID 500	350	568,6	604,6
ID 600	355	684,8	723,8
ID 800 injection	280	917,0	970,0
ID 800 rotomold	324	917,0	1027,0
ID 1000	365	1121,1	1252,1
ID 1200	435	1343,3	1481,3

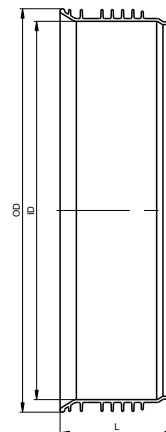
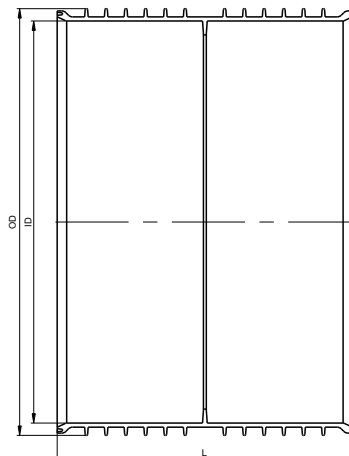



Гумица Gasket			
PPHM "ID"			
Гумица Gasket	Димензии Dimensions		
	ID	b	h
	(mm)	(mm)	(mm)
ID 100	79	47	32
ID 200	160	18	19
ID 250	201	19	21,5
ID 300	246	26	25
ID 400	358	34	33
ID 500	420	38	40
ID 600	505	55	49
ID 800	680	62	63
ID 1000	873	69	68
ID 1200	1055	95	53

