



KONTI
HIDROPLAST®

PRODUCTION OF POLYETHYLENE
AND POLYPROPYLENE PIPES

POLYPROPYLENE SEWAGE PIPES



PPHM HIGH PERFORMANCE PIPES

www.konti-hidroplast.com.mk



CONTENTS

INTRODUCTION	2
PP – THE MATERIAL OF THE FUTURE	5
PIPE CONSTRUCTION	5
PROPERTIES OF THE HIGH PERFORMACE SEWAGE PIPE	8
TRANSPORTATION AND STORAGE	9
INSTALLATION	9
SUPPORT AND EMBEDDING	10
CUTTING TO LENGTH AND BEVELLING	11
SETTING UP THE CONNECTION AT PIPES AND FITTINGS	11
CONNECTION TO CONSTRUCTIONS	11
WATERTIGHT TEST	12
REFERENCE STANDARD FOR PPHM HIGH PERFORMANCE PIPE	13
FITTINGS	14
CERTIFICATES	20
LABORATORY TESTING	21



KONTI HIDROPLAST®

WELCOME TO OUR WORLD

Konti Hidroplast is part of the world's largest manufacturer and supplier of high performance plastic pipes and offers the best and the most cost effective pipe systems for its customers.

Konti Hidroplast specialises in polyethylene pipe systems for gas and water transportation in the utilities and industrial markets.

MARKET ORIENTED

Konti Hidroplast products find a broad range of applications in the industrial and utilities market on a worldwide scale.

The water and gas distribution enterprises are important sectors for high integrity products where the maintenance of water quality and the safe transport of gaseous fuels are of paramount importance.

Industrial applications include alternative energy installations in landfill gas systems to effluent transportation and mineral slurry.

Products are widely used in pipeline installation, repair and maintenance.

Many of the brands in the Konti Hidroplast portfolio have a long record of innovation in meeting the needs of the water and gas utilities.

Being one of the foremost pioneers in polyethylene pipe systems, Konti Hidroplast is continually improving and updating its offer to meet the ever growing needs of the distribution engineer; ensuring they stay at the forefront of world gas and water distribution/treatment systems.





CUSTOMER FOCUS

The key to our success lies in the commitment to provide the highest quality service and support. We are a team of highly motivated and experienced individuals.

We place the utmost importance on meeting the needs of our customers, constantly evolving our extensive product portfolio to meet the ever changing demands of the water and gas utilities, industrial and foreign markets.

QUALITY

Konti Hidroplast is a result-driven business – its people, products and service. Designed, manufactured and supplied under EN ISO 9001:2000 accredited Quality Management Systems, Konti Hidroplast products comply with relevant national, European and international product standards to ensure complete reliability for our customers.

Besides the ISO certificates for Quality Management Systems and ecology, the gas pipes are also certified by DVGW CERT GmbH.

THE ENVIRONMENT

Committed to sustainable manufacture and systems, Konti Hidroplast operates and maintains an environmental policy fully accredited by ISO 14001.

PP – THE MATERIAL OF THE FUTURE

Polypropylene (PP) is a thermoplastic material belonging to the group of polyolefins. These plastics have already been used with great success in pipe production for several decades. PP fulfills the strictest requirements with regard to the environment and technology.

MATERIAL

Polypropylene, high modulus, PPHM, PP-b (block polypropylene) co-polymer. Material characteristics:

DESCRIPTION	UNIT	STANDARD	VALUE
MFI	Gr/10 min	ISO 1133/ (230 C°/2.16)	0.3
DENSITY	kg/m ³	ISO 1183	900
FLEXURAL MODULUS	MPa	ISO 527-2	1500-2000
TENSILE STRENGTH AT YIELDS 26 C°	MPa	ISO 527-2	35
CHARPY NOTCHED IMPACT STRENGTH	kJ/m ²	+23 C° - 20 C°	50 2.2

PIPE CONSTRUCTION

SOLID WALL PIPE

DESCRIPTION: PPHM SOLID PIPE is a state-of-the-art system of pipes and fittings for external sewage systems. The system components are made of top quality, filler free, PP-b block polypropylene co-polymer.

FOR DESIGNERS: PPHM SOLID PIPE, polypropylene smooth pipe, made of a block co-polymer, without a filler, for outdoor sewage systems.

PRODUCTION: PPHM SOLID PIPE are produced by standard extrusion process of PP pipe.

COLOUR: Orange Brown

CONNECTION: Push-fit connection with very good watertightness of up to 2.5 bar and firmly inserted EPDM. This kind of pipe can be combined with all other kinds of standardized plastic pipes and fittings due to its standard outside diameter.

PRODUCTION STANDARD: EN 1852-1

AREA OF APPLICATION: Its application area is for heavy duty underground sewer and waste water pipe systems with highest demands, as:

- High groundwater levels
- Flooded plains
- High moving loads with low top fills
- Development of new areas with sewer replacement

DIMENSION RANGE:

- From DN / OD 160 up to 400 mm with a complete range with full range of fittings.
- Available in different stiffness classes SN 8 KN/m²; SN 10 KN/m²; SN 12 KN/m² and SN 16 KN/m².

TRIPPLE LAYER PIPE - PP ML COMPACT PIPE

DESCRIPTION: PP ML COMPACT PIPE is Polipropilene Multi Layer compact pipe for non-pressure underground drainage and sewerage – a structured triple wall piping system with smooth internal and external surface and system, profile Type A1. PP ML compact pipes are made of high modulus polypropylene (PP-HM) as basic material, with three layers. Each of the three layers has different modified formula of the basic material that gives specific performance on the total quality of the pipe.

FOR DESIGNERS: PP ML COMPACT, polypropylene multilayer smooth pipes, made of a polypropylene block co-polymer with a high modulus and high performance modified material in three layers.

PRODUCTION: The 3-layer structure of the PP ML compact pipe requests high-tech production equipment. Three different layers are combined to make a sewer pipe with exceptional characteristics using a multilayer extrusion system and new production technology. The new technology ensures compact structure of wall thickness. The compact structure is without any splitting or de-lamination.

• INTERNAL LAYER

Made of modified PP that guarantees high chemical and abrasive resistance. The smooth surface inside ensures a good flow and prevents incrustation.

• MIDDLE LAYER

Impact resistant layer even at very low temperature.

• OUTER LAYER

Made of high quality PP, filled with mineral modifier; highly resistant to atmospheric agents and surface damage. The modified formula of PP ensure high UV protection which enables outdoor storage.

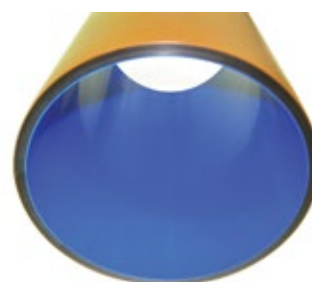
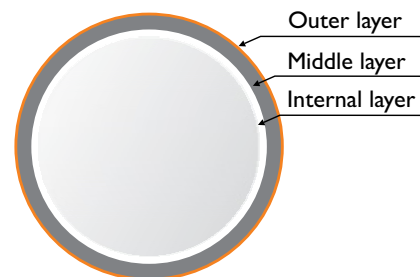

COLOUR: Outside orange brown / middle black and inside light color.

Can be made by customer request .

CONNECTION: Push-fit connection with very good watertightness of up to 2.5 bar and firmly inserted EPDM. This kind of pipe can be combined with all other kinds of standardized plastic pipes and fittings due to its standard outside diameter.

PRODUCTION STANDARD:

EN 13476-2:2007 (Type A1)

ONR 201513:2011

Protective
Strong
Resistant

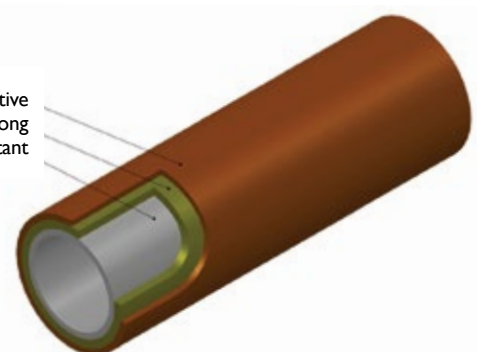

AREA OF APPLICATION: With a performance of:

- Stiffness
- Flexibility
- Light inside layer
- Abrasion resistance
- Environmentally friendly, halogen free

PP ML COMPACT triple layer sewer pipe is used everywhere where the advantages of thermoplastics are desirable and high rigidity is also required.

The most demanded applications:

- Municipality drainage
- Industry
- Airports
- Extreme wheel loads
- Liquidised soil

DIMENSION RANGE: From DN / OD 160 up to 400 mm with a complete range with full range of fittings. Available in different stiffness classes SN 8 KN/m²; SN 10 KN/m²; SN 12 KN/m² and SN 16 KN/m².



PROPERTIES OF HIGH PERFORMANCE SEWAGE PIPE

- The highest quality of PP-b block polypropylene co-polymer, offering very good impact resistance achieved even at low temperatures
- The highest stiffness class of SN 8, SN 10, SN 12 and SN 16 for the complete product range of pipes and fittings
- Point load resistance
- Very high abrasion resistance
- Excellent impact resistance and extremely tough
 - does not tend to crack or spread cracks
 - robust under mechanical stress (i.e. high-pressure flushing)
- Advanced chemical and thermal loading capacity
- Smooth interior surface
- High wall thicknesses
- Very good chemical resistance (PH values 1-13)
- Suitable for heavy vehicles traffic
- Service life of 100 years
- Temperature resistance (over short period up to 90 C°, for longer periods up to 60°C)
- Easy handling
- Completely recyclable and free of halogens and heavy metals

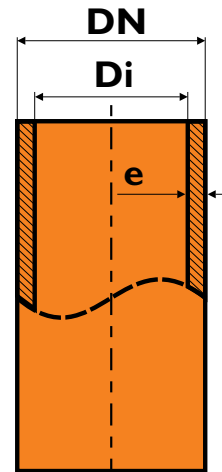

Temperature - ranges of application

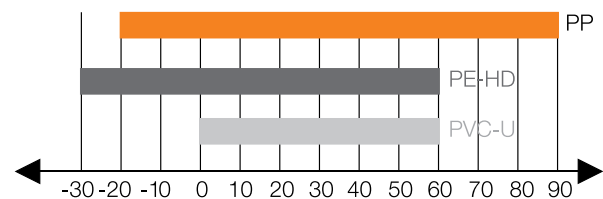

PROPERTIES OF SEWER PIPE MATERIALS

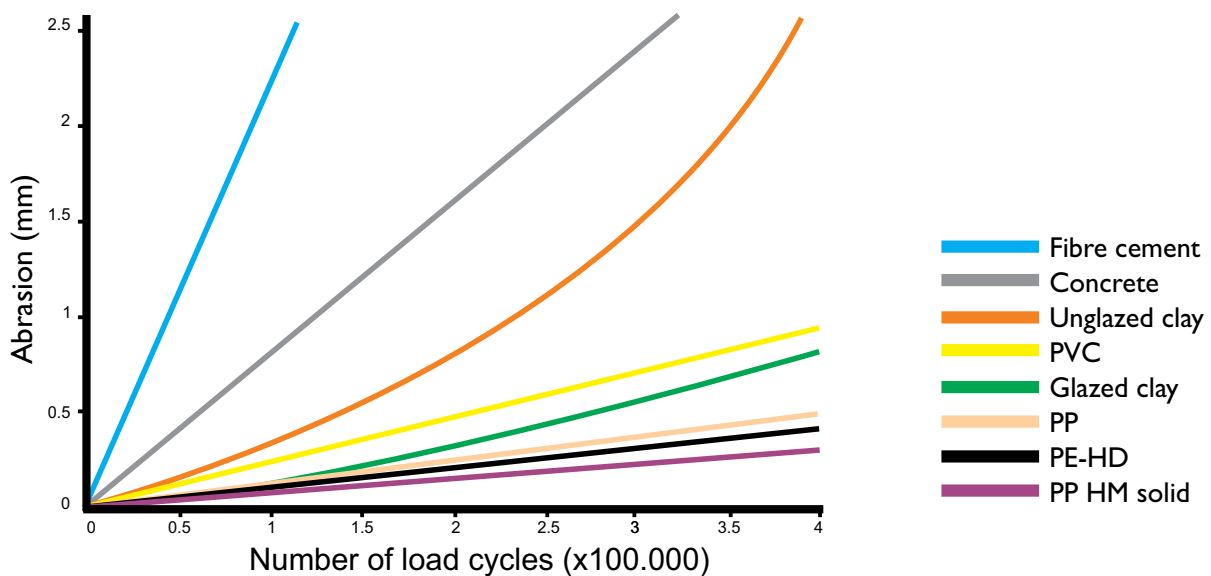

Table of pipe dimension and pressure classes

SERIE SN 8 KN/M ² SDR 29 S 14			SERIE SN 10 KN/M ² (FLEXURAL MODULUS 1800 MPA) SERIE SN 12 KN/M ² (FLEXURAL MODULUS 2000 MPA) SDR 26 S 12.5			SERIE SN 16 KN/M ² SDR 22 S 10.5		
DN	Di	e	DN	Di	e	DN	Di	e
160	149.0	5.5	160	147.60	6.2	160	145.40	7.3
200	186.2	6.9	200	184.60	7.7	200	181.80	9.1
250	232.80	8.6	250	230.8	9.6	250	227.20	11.40
315	293.40	10.8	315	290.70	12.1	315	286.20	14.4
400	372.60	13.7	400	369.40	15.3	400	363.60	18.2
500	465.40	17.1	500	461.80	19.1	500	454.40	22.80
630	586.8	21.6	630	581.8	24.1	630	572.6	28.7

COMPLETE SYSTEM

HIGH PERFORMANCE SEWAGE PIPE system includes pipes and numerous fittings which are required for planning and construction of a functional sewer system. The fittings are injection molded. Naturally, PPHM pipe system can be combined with typical standardized plastic pipe systems due to its standard outside diameter.

TRANSPORTATION AND STORAGE

The pipes and fittings are to be protected against damage. The pipes should be supported over their entire length during transport in order to avoid sagging. Impact stress – especially under freezing temperatures – must be avoided. Pipes and fittings may be stored outdoors.

The following measures must be taken when storing pipes:

- Pipes must be stored in such a manner that perfect support is ensured and no deformations can occur.
- The pipe layers can be stored both with and without wood in between them.
- When storing, the pipe sockets should be horizontally and vertically unhampered.
- A stacking height of 2 meters should not be exceeded.

Rubber sealing elements, if not protected, should not be stored outside for long periods.

INSTALLATION

The following instructions apply for utilization and installation of PPHM high performance sewage pipes and fittings made of polypropylene (PP), which serve as non-pressure underground pipes for drainage of waste water according to EN 1851-2, EN 13476-2 :2007 (Type A1) ONR 20513:2011 and EN 1610.

- In normal load condition, installation deformation is allowed up to 6%
- At special condition, like difficult condition of construction, deformation allowed ≤ 8%
- At special cases, due to the pronounced subsidence ≤ 15%

SUPPORT AND EMBEDDING

Pipes can be laid in consistent, relatively loose, fine-grained soil if a support along the entire length is possible. At the sockets, hollows are to be made in the lower embedding area so that the connection can be properly carried out. The hollows must not be larger than necessary in order to carry out proper connections. Should the soil in question be unsuitable as a support, the ditch bed must be dug deeper and a support must be made. The thickness of the lower embedding layer must not exceed the following:

- 100 mm in the case of normal soil
- 150 mm in the case of stones or compact soil

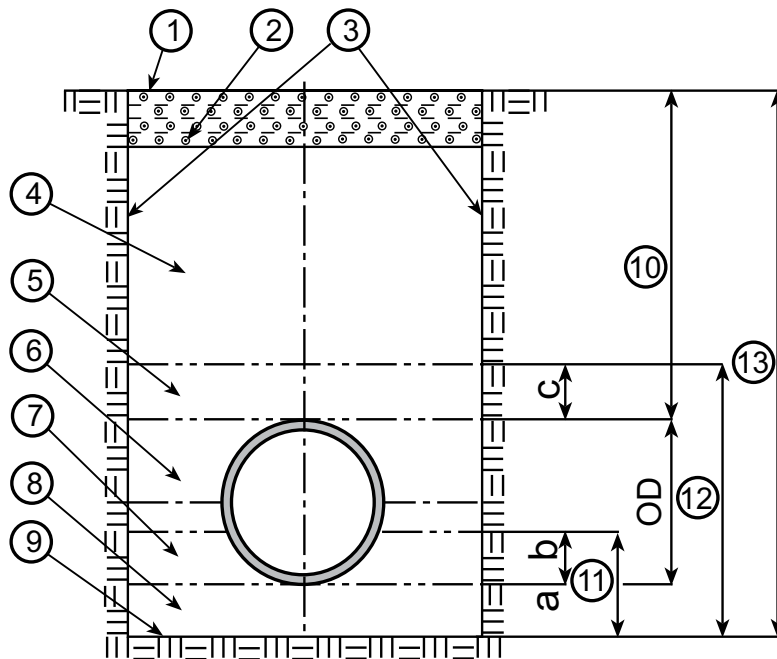

- | | | |
|---|----------------------------------|---|
| 1. Surface | 7. Upper bedding layer | 13. Ditch depth |
| 2. Lower edge of the road or rail structure, if present | 8. Lower bedding layer | a. Thickness of the lower bedding layer |
| 3. Ditch walls | 9. Ditch bed | b. Thickness of the upper bedding layer |
| 4. Main filling (3.6) | 10. Cover height | c. Thickness of the cover |
| 5. Cover (3.5) | 11. Thickness of embedding | |
| 6. Side filling (3.12) | 12. Thickness of the piping area | |

The thickness of the upper embedding layer should be carried out in such a manner that the structural analysis conditions are fulfilled and a support angle of 180° is achieved, i.e. generally $0.5 \times DA$. Should the ditch bed prove not to have sufficient supporting properties, special measures are required. Should, due to the construction, a concrete slab be necessary in the area on which the pipes rest, it is recommended that provision is made for an intermediate layer of suitable soil between the pipe and slab. This layer should be 150 mm under the pipe shaft and 100 mm under the connection.

Should, for structural reasons, additional steps for installment be considered essential, a concrete slab above the covering area is recommended instead of a concrete jacket for load distribution purposes. Should a concrete jacket be planned, it is to be produced in such a manner that the entire structural load can be absorbed by the jacket.

CUTTING TO LENGTH AND BEVELLING

If necessary, pipes may be cut to length with a suitable plastic cutter or fine-toothed saw. Cuts are to be made at right angles to the pipe axis. A guiding frame may be useful.

The cutting edges must be trimmed. The pipe ends must be bevelled at an angle of approx. 15°, as in the illustration, using either a suitable tool for bevelling or a coarse file.

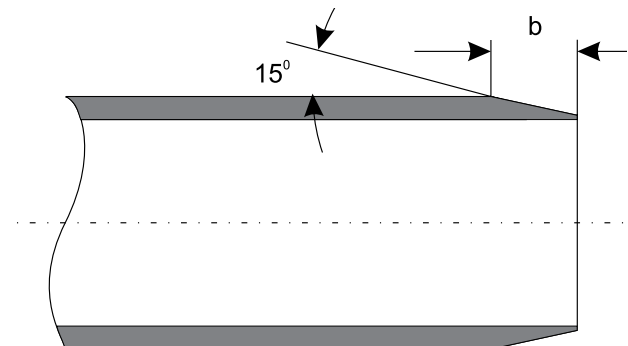

SETTING UP THE CONNECTION AT PIPES AND FITTINGS

- Remove any dirt from the inserting end (spigot end) and sockets and, if necessary, from the sealing element.
- Check the position of the sealing elements and make sure they are in perfect condition.
- Coat the bevelling of the inserting end evenly with a lubricant. Do not use any oil or grease!
- Push the inserting end into the socket until it resists and make a marking on the edge of the socket with a pencil or a felt-tip pen. Finally the pipe end must be pulled approx. 3 mm per metre of installed total length. It must, however, be pulled out at least 10 mm. The installation of couplers and double sockets is carried out in the same manner.



CONNECTION TO CONSTRUCTIONS

Connections to constructions (chambers etc.) are to be carried out with joints using chamber inner linings. Sealing between the chamber inner lining and the sewer pipe is carried out by means of a rubber sealing ring.

WATERTIGHT TEST

Checking to see that piping, shafts and inspection openings are watertight is either to be carried out with air (procedure "L") or with water (procedure "W") according to EN 1610. In the case of procedure "L" the number of corrective measures and repeated checks in the case of failure is unlimited. In the case of the "L" procedure, the number of corrective measures and repeated checks in the case of failure is unlimited. The result of the water test is then decisive.

TESTING WITH WATER

All openings of the section of piping are to be checked, branches and junctions are also to be closed in a watertight manner and secured against pressure and being pressed out.

It is recommended – particularly in the region of the property – that a large number of fittings be anchored by means of driving in posts or by means of anchoring them with appropriate locking clamps so that any changes in position are avoided.

In straight pipelines, too, pipes and inspection stoppers are to be supported accordingly against horizontal pressure. The piping, if not covered, is to be secured against changes in position. The piping is to be filled with water in such a manner that it is free of air. Therefore, it makes sense to fill the pipes slowly from the lowest point, so that the air present in the pipes can escape from the sufficiently-large air release points at the highest point of the piping.

Sufficient time (one hour) is to be provided between filling and checking the piping in order to allow any air flowing into the pipes on filling and remaining there to gradually escape. The pressure test is to be taken at the lowest point in the part to be checked. Non-pressure pipes are to be checked with 0.5 bar excess pressure. The test pressure, which must have been achieved prior to testing, has to be maintained for 30 minutes in accordance with EN 1610.

If necessary, the quantity of water required is to be constantly filled and gauged. The test requirements are fulfilled when the volume of water added in 30 minutes is not more than 0.15 l/m² for pipes.

PLEASE NOTE: m² describes the moistened inner surface.

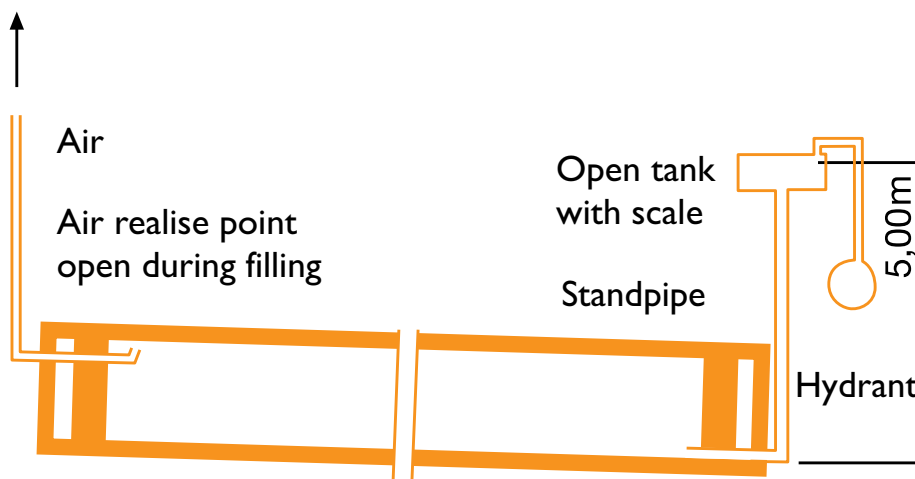

REFERENCE STANDARD FOR PPHM HIGH PERFORMANCE PIPE

EN 1852-1

Plastic piping system for non-pressure underground drainage and sewerage – PP (Polypropylene) – Specification for pipes, fittings and systems.

PrEN 1852-2

Plastic piping system for non-pressure drainage and sewerage – Polypropylene (PP) – Guidance for the assessment of conformity

ISO 9969

Thermoplastic pipes – Determination of ring stiffness

EN 1610

Construction and testing of drain and sewage

EN 13476-2

Plastics piping systems for non-pressure underground drainage and sewerage. Structured-wall piping systems. Specifications for pipes and fittings with smooth internal and external surface and the system, Type A

ONR 20513:2011

Multilayer piping systems (PP-ML) for non-pressure underground drainage and sewerage of reinforced Polypropylene-Compound/-Blend – Dimensions, requirements, tests, proof of conformity



PPHM HIGH PERFORMANCE FITTINGS

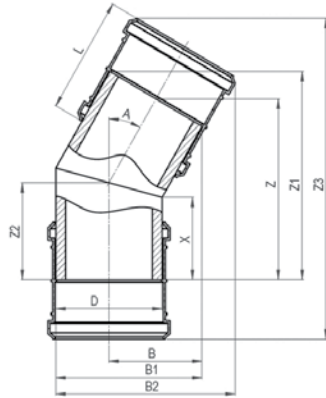

ELBOW 11°	DIMENSIONS										
	D	A	X	Z	Z1	Z2	Z3	B	B1	B2	L
	(mm)	(°)	(mm)	(mm)	(mm)	(mm)	(mm)	(mm)	(mm)	(mm)	(mm)
Φ160*	160	11	150	313	328	158	496	109	189	217	165
Φ200*	200	11	150	316	335	160	553	129	229	262	215
Φ250*	250	11	200	420	444	212	687	163	288	324	240
Φ315*	315	11	250	525	556	265	848	205	363	403	290
Φ400	400	11	250	534	572	269	924	248	448	494	350

ELBOW 22°	DIMENSIONS										
	D	A	X	Z	Z1	Z2	Z3	B	B1	B2	L
	(mm)	(°)	(mm)	(mm)	(mm)	(mm)	(mm)	(mm)	(mm)	(mm)	(mm)
Φ160*	160	22	150	319	349	166	513	136	216	260	165
Φ200*	200	22	150	327	364	169	576	156	256	309	215
Φ250*	250	22	200	432	479	224	715	200	325	383	240
Φ315*	315	22	250	541	600	281	884	251	409	476	290
Φ400	400	22	250	557	632	289	974	294	494	572	350

ELBOW 30°	DIMENSIONS										
	D	A	X	Z	Z1	Z2	Z3	B	B1	B2	L
	(mm)	(°)	(mm)	(mm)	(mm)	(mm)	(mm)	(mm)	(mm)	(mm)	(mm)
Φ160*	160	30	150	320	360	171	519	155	235	284	165
Φ200*	200	30	150	330	380	177	586	175	275	337	215
Φ250*	250	30	200	436	498	233	727	225	350	418	240
Φ315*	315	30	250	545	624	292	900	283	440	521	290
Φ400	400	30	250	567	667	304	998	325	525	621	350

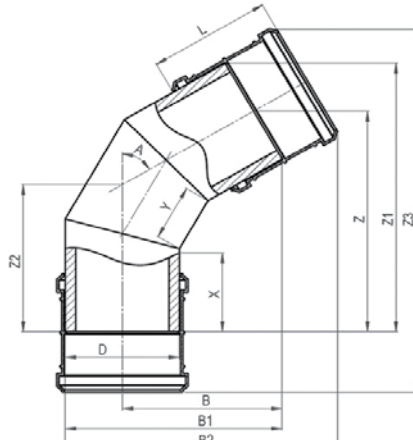

ELBOW 45°	DIMENSIONS										
	D	A	X	Y	Z	Z1	Z2	B	B1	B2	L
	(mm)	(°)	(mm)	(mm)	(mm)	(mm)	(mm)	(mm)	(mm)	(mm)	(mm)
Ø160*	160	45	150	90	396	452	603	221	301	369	165
Ø200*	200	45	150	110	428	499	693	248	348	434	215
Ø250*	250	45	200	130	550	638	853	316	441	536	240
Ø315*	315	45	250	170	695	807	1064	399	557	669	290
Ø400	400	45	250	160	716	857	1166	438	638	772	350

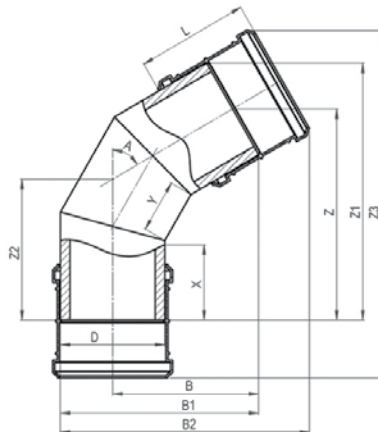

ELBOW 60°	DIMENSIONS											
	D	A	X	Y	Z	Z1	Z2	Z3	B	B1	B2	L
	(mm)	(°)	(mm)	(mm)	(mm)	(mm)	(mm)	(mm)	(mm)	(mm)	(mm)	(mm)
Ø160*	160	60	150	100	381	450	254	584	260	340	421	165
Ø200*	200	60	150	100	398	485	265	656	280	380	483	215
Ø250*	250	60	200	130	521	629	347	819	363	488	602	240
Ø315*	315	60	250	150	641	778	428	1005	449	607	742	290
Ø400	400	60	250	150	678	851	452	1124	492	692	853	350

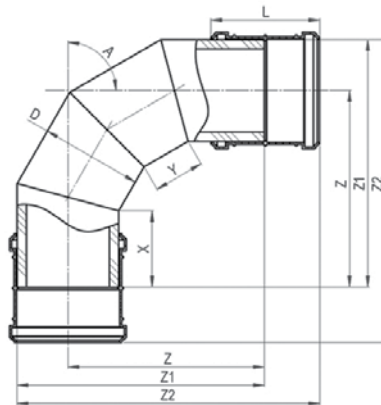

ELBOW 90°	DIMENSIONS							
	D (mm)	A (°)	X (mm)	Y (mm)	Z (mm)	Z1 (mm)	Z2 (mm)	L (mm)
Ø160*	160	90	150	100	367	447	529	165
Ø200*	200	90	150	100	387	487	594	215
Ø250*	250	90	200	130	503	628	748	240
Ø315*	315	90	250	150	612	770	915	290
Ø400	400	90	250	150	655	855	1030	350

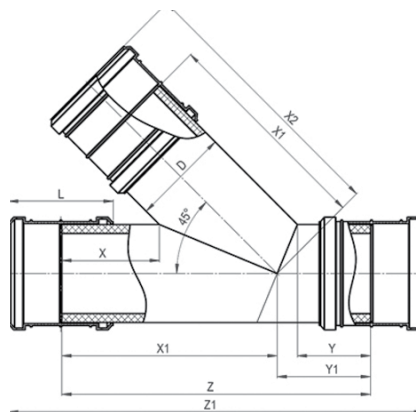

Y-BRANCH REDUCER	DIMENSIONS									
	D (mm)	A (°)	X (mm)	X1 (mm)	X2 (mm)	Y (mm)	Y1 (mm)	Z (mm)	Z1 (mm)	L (mm)
Ø160*	160	45	200	393	476	150	183	576	741	165
Ø200*	200	45	200	441	549	150	191	633	848	215
Ø250*	250	45	250	552	672	200	252	804	1044	240

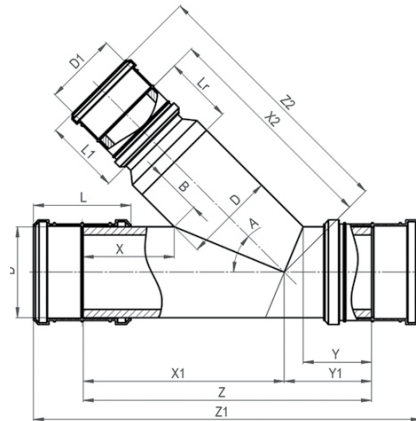

Y-BRANCH REDUCER	DIMENSIONS														
	D	D1	A	X	X1	X2	B	Y	Y1	Z	Z1	Z2	Lr	L	L1
	(mm)	(°)	(mm)	(mm)	(mm)	(mm)	(mm)	(mm)	(mm)	(mm)	(mm)	(mm)	(mm)	(mm)	(mm)
Φ160×110	160	110	45	200	393	533	200	150	183	576	746	603	140	165	140
Φ160×125	160	125	45	200	393	513	200	150	183	576	746	583	120	165	140
Φ200×160	200	160	45	200	441	591	200	150	191	633	853	674	150	215	165
Φ250×200	250	200	45	250	552	672	200	200	252	804	1049	779	170	240	215

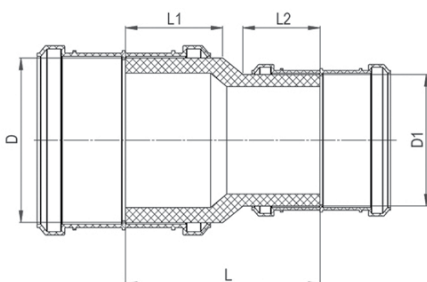

REDUCER	DIMENSIONS				
	D	A	X	X1	X2
	(mm)	(°)	(mm)	(mm)	(mm)
Φ160×110	160	110	200	95	80
Φ160×125	160	125	200	95	80
Φ200×160	200	160	240	120	95
Φ250×200	250	200	270	130	120
Φ315×250	315	250	320	155	130
Φ400×315	400	315	380	185	155

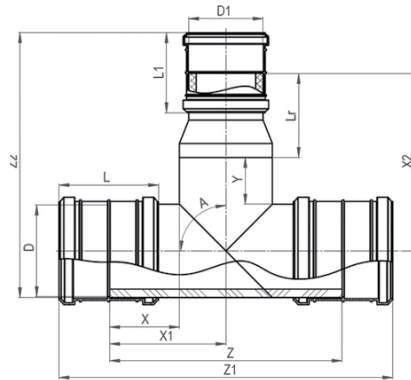

TEE REDUCER	DIMENSIONS												
	D	D1	A	X	X1	X2	Y	Z	Z1	Z2	Lr	L	L1
	(mm)	(mm)	(°)	(mm)	(mm)	(mm)	(mm)	(mm)	(mm)	(mm)	(mm)	(mm)	(mm)
Φ160x110	160	110	90	150	230	320	100	460	630	475	140	165	140
Φ160x125	160	125	90	150	230	300	100	460	630	455	120	165	140
Φ200x160	200	160	90	150	250	350	100	500	720	538	150	215	165
Φ250x200	250	200	90	200	325	395	100	650	895	633	170	240	215
Φ315x250	315	250	90	200	358	458	100	715	1010	740	200	290	240
Φ400x315	400	315	90	250	450	530	100	900	1255	880	230	350	290

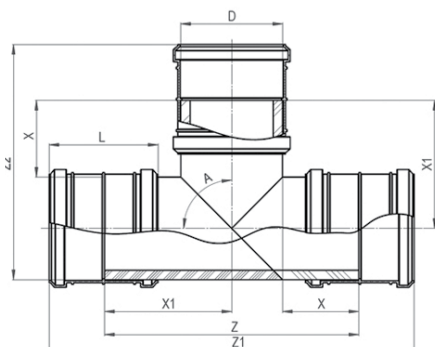

TEE REDUCER	DIMENSIONS						
	D	A	X	Z	Z1	Z2	L
	(mm)	(°)	(mm)	(mm)	(mm)	(mm)	(mm)
Φ160*	160	90	150	460	625	393	165
Φ200*	200	90	150	500	715	458	215
Φ250*	250	90	200	650	890	570	240
Φ315*	315	90	200	715	1005	660	290
Φ400	400	90	250	900	1250	825	350

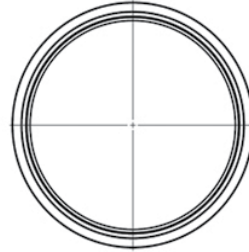
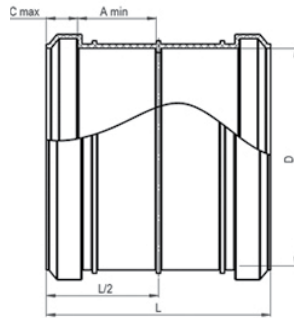

SOCKET	DIMENSIONS					
	A min (EN 12666 стандард)	C max (EN 12666 стандард)	A min (измерено)	C max (измерено)	D	L
	(mm)	(mm)	(mm)	(mm)	(mm)	(mm)
Φ160*	50	50	50	30	160	165
Φ200*	58	58	70	35	200	215
Φ250*	68	68	85	35	250	240
Φ315*	81	81	95	45	315	290
Φ400	98	98	120	50	400	350

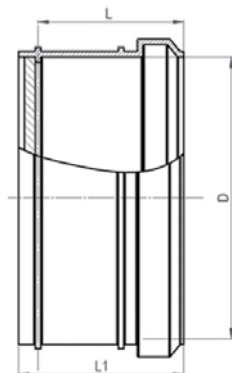

END CAP	DIMENSIONS		
	D	L	L1
	(mm)	(mm)	(mm)
Φ160*	160	83	93
Φ200*	200	108	118
Φ250*	250	120	130
Φ315*	315	145	155
Φ400	400	175	185

CERTIFICATES



LABORATORY TESTING

MELT-MASS FLOW RATE



VOLATILE CONTENT



DENSITY

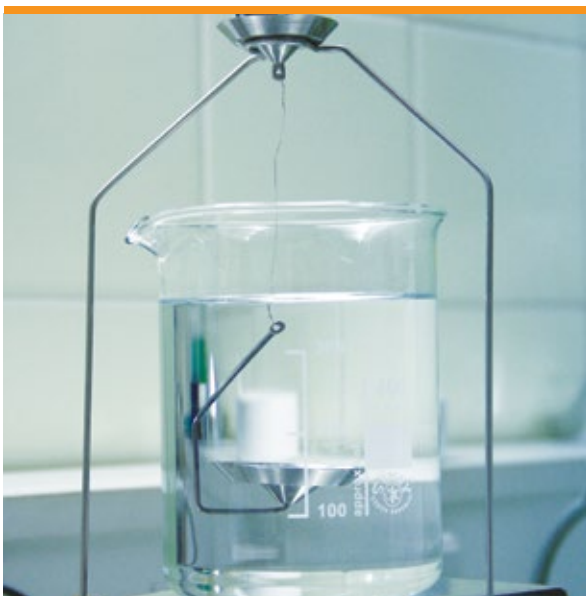

ELONGATION AT BREAK



HYDROSTATIC STRENGTH AT 80°C AND 20°C





**KONTI
HIDROPLAST®**



MACEDONIA
1480 Gevgelija, Industriska bb



+389 34 212 064 +389 34 215 225
+389 34 211 757 +389 34 215 226



+389 34 211 964



contact@konti-hidroplast.com.mk
hidroplast@t-home.mk



www.konti-hidroplast.com.mk



qualityaustria
SYSTEM CERTIFIED
ISO 9001:2008 No. 01442/0
ISO 14001:2004 No. 00211/0

EXACT

IGH