



KONTI
HIDROPLAST®

PRODUCTION OF POLYETHYLENE
AND POLYPROPYLENE PIPES



**HIGH RIGIDLT
Y
MANHOLE
PE/PP**

www.konti-hidroplast.com.mk

KONTI
HIDROPLAST

KONTI HIDROPLAST KONTI

CONTENTS

INTRODUCTION.....	2
PE/PP HIGH RIGIDITY MANHOLE UPTO SN 8 STIFFNESS CLASS.....	5
THE ADVANTAGES OF PLASTIC (HDPE/PP) MANHOLES.....	7
HDPE/PP MATERIAL SPECIFICATIONS.....	9
KONTI KAN MANHOLE	10
KONTI SPIRAL MANHOLE	14
INSTALATION OF MANHOLE	17
STANDARDS.....	20



KONTI HIDROPLAST®

WELCOME TO OUR WORLD

Konti Hidroplast is part of the world's largest manufacturer and supplier of high performance plastic pipes and offers the best and most cost effective pipe systems for its customers.

Konti Hidroplast specialises in polyethylene pipe systems for gas and water transportation in the utilities and industrial markets.

MARKET ORIENTED

Konti Hidroplast products find a broad range of applications in the industrial and utilities market on a worldwide scale.

The water and gas distribution enterprises are important sectors for high integrity products where the maintenance of water quality and the safe transport of gaseous fuels are of paramount importance.

Industrial applications include alternative energy installations in landfill gas systems to effluent transportation and mineral slurry.

Products are widely used in pipeline installation, repair and maintenance.

Many of the brands in the Konti Hidroplast portfolio have a long record of innovation in meeting the needs of the water and gas utilities.

Being one of the foremost pioneers in polyethylene pipe systems, Konti Hidroplast is continually improving and updating its offer to meet the ever growing needs of the distribution engineer; ensuring they stay at the forefront of world gas and water distribution/treatment systems.





CUSTOMER FOCUS

The key to our success lies in the commitment to provide the highest quality service and support. We are a team of highly motivated and experienced individuals.

We place the utmost importance on meeting the needs of our customers, constantly evolving our extensive product portfolio to meet the ever changing demands of the water and gas utilities, industrial and foreign markets.

QUALITY

Konti Hidroplast is a result-driven business – but also a business driven by its people, products and service. Designed, manufactured and supplied under EN ISO 9001:2000 accredited Quality Management Systems, Konti Hidroplast products comply with relevant national, European and international product standards to ensure complete reliability for our customers.

Besides the ISO certificates for Quality Management Systems and ecology, the gas pipes are also certified by DVGW CERT GmbH.

THE ENVIRONMENT

Committed to sustainable manufacture and systems, Konti Hidroplast operates and maintains an environmental policy fully accredited by ISO 14001.

PE/PP HIGH RIGIDITY MANHOLE UP TO SN 8 STIFFNESS CLASS

MANHOLES

To offer the possibility to control and maintain pipe system regularly, manholes are integrated in the system. The Manhole System of Konti Hidroplast is a modern, highly developed system of chamber components. It can be used for the construction of canalization inspection chambers and inlets where the conditions are challenging. The Manhole chamber system was designed and produced according to the latest cognitions of the plastics technology and the requirements of engineering and underground construction.

The Manhole system of Konti Hidroplast is multifunctional enough to offer suitable solutions for numerous problems at the construction site.

All components can be easily and quickly connected to each other, as well as to other pipe systems, especially because the manhole systems are made of the same material as the pipes, and are also connected to the system with similar jointing techniques. That ensures the same dimension and construction, and creates a good waterproof stable and secure system.

Perfect connections and integrated sealing systems guarantee a tight connection in each area of application.



APPLICATION

HDPE/PP manholes are custom fabricated for many varied applications, including:

- Municipal and industrial manholes,
- Sewer and storm water manholes,
- Leachate collection,
- Sewer lift stations,
- Siphon structures,
- Pump stations,
- Bio treatment of sewerage,
- Wet wells and sumps with both single wall and dual contained options.

SPECIAL PURPOSE

HDPE/PP manholes serve many specialized purposes. Whatever your application requirements, a custom designed HDPE/PP manhole structure could be the answer. Many hazardous and/or toxic materials-handling problems are solved by using HDPE/PP fabricated structures.

The pictures below show different construction of manhole. Any other request can be custom made.



Compact cascade manhole



Tangential manhole



Compact standard manhole with standard bottom flow

THE ADVANTAGES OF PLASTIC (HDPE/PP) MANHOLES

The first and very important advantage is that the Manhole is one homogenous system of a single material structure for all consisting parts of the manhole (bottom, body, cone, ladders), good welded and making a compaction structure.

HDPE/PP manholes are the most trouble-free manholes for a long service life.

1 – HDPE manholes are light-weight and easy to install. Light equipment can be used to position these manholes.

2 – HDPE offers a wide range of chemical resistance to acids, bases, and many organic compounds. Because of this resistance, attack from hydrogen sulfide, sulfuric acid and other aggressive chemicals does not occur.

3 – In sanitary sewers, hydrogen sulfide is the primary cause of corrosion. Hydrogen sulfide is converted to sulfuric acid, which attacks the concrete and eventually destroys concrete manholes and pipe. HDPE is highly resistant to such chemical attack and hence HDPE manholes are best suitable for sanitary systems.

4 – Inlets and outlets are positioned by specific standard construction or can be custom made each piece, as per site requirement, during the manufacturing process. These inlets and outlets are factory welded into place to be leak-free.

5 – The Industrial effluent is most often corrosive and may also be abrasive as well. Since high density polyethylene pipe and manholes are corrosion and abrasion resistant, they work well for many industrial and chemical applications.

6 – Lifting lugs can be fabricated on the HDPE manhole when requested.

7 – HDPE ladders can be fabricated inside the HDPE manhole when requested.

8 – The benched or half pipe-formed bottom is available connecting to inlet and outlet. A benched bottom adds significant improvement in the flow of water.



9 – HDPE manholes are fabricated with custom made inlets and outlets to accept HDPE plain wall pipes, HDPE corrugated pipes, HDPE profiled pipes or uPVC pipes.

1. Polyethylene
2. Cast Iron
3. Polypropylene
4. Clay
5. GRP (Fiberglass)
6. PVC
7. Corrugated pipes



10 – HDPE manholes can be used under heavy traffic loads, by following recommended installation methods.

11 – HDPE manholes can be used with underground water tables by providing recommended anti floatation installation.

12 – Operating services temperatures may be from (-45°C) or lower, up to (+70°C). Under some circumstances, the HDPE manholes may handle fluids at temperatures up to (70°C).

13 – Black polyethylene material used to make HDPE manholes contains a minimum of 2% carbon black for resistance to degradation from ultraviolet light. Before installation manholes may be stored outdoors and unprotected for very long period. Colored manholes can be stored outdoor without protection not longer then 6 months.

HDPE/PP MATERIAL SPECIFICATIONS

CHARACTERISTICS	TEST METHOD	UNIT	LIMIT	
			PE	PP
MFI	EN ISO 1133	G/10 MIN PE (190/5) PP (230/2.16)	0.2-1.5	0.2-1.5
DENSITY	EN ISO 1183	G/CM3 PE PP	0.935-0.955	0.900
FLEXURAL MODULUS	EN ISO 178	MPA	1200	1300-1500

STRUCTURE

HDPE and PP manhole can be structured as:

- KONTI KAN MANHOLE
- KONTI SPIRAL MANHOLE

KONTI KAN MANHOLE

The compact structure of the manhole consists of good integration of all consisting part, extrusion welded:

ITEM NO.	PART NAME
1	Corrugated pipe – body of the Manhole
2	Double bottom with injection molded flow
3	Side connector to the manhole bottom
4	Steps
5	Cone

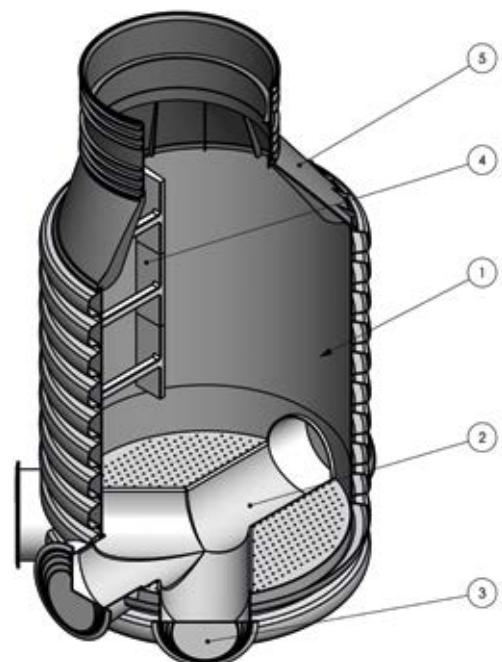



This kind of manholes is intended for high depth installation of 6 m even deeper.

Because of safety reason they are compact, meaning all composition part are welded and all make up a compact integrated manhole structure.

Made by EN 13598-2 standard.

Available in two options as HDPE or PP.

Available in diameter of ID 800/1000 and 1200.

Application is in heavy condition projects, meaning high depth and needing very rigid stiffness structure for all integrated parts.

That means that the ring stiffness should not be less than SN 8 measured according to ISO EN 9969

1. BODY OF THE MANHOLE IS MADE OF DOUBLE WALL (PE OR PP) PIPE

It is connected on top or bottom with extrusion welding . It is made of high stiffness PE (PP) double wall corrugated pipe. Stifness is very high to resist the earth's side forces, and the vertical traffic load as well. Usually for deep underground manhole stiffness class of SN 8 by EN 9969 is used.

The Manhole body can be made in dimension range of:

MANHOLE BODY DIMENSION	ID 600	ID 800	ID 1000	ID 1200

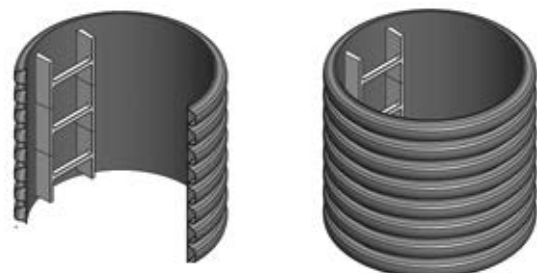

2. INJECTION MOLDED FLOW BOTTOM

Usually the lowest part of the manhole is completely fabricated out of polyethylene (or PP) with double bottom according to the standard requirements. It consists of flat plate and injection molded flow, welded all together to make good strengthened bottom structure.



It is made with 3 inlets and one outlet. It can be adapted according to need to any requested dimensions. Available and possible side connections:

ID	100	160	200	250	300	400	500	600
OD	110	160	200	250	315	400	500	630

The structural integrity of bases is tested by **EN 14830** standard.

2.1. FLAT DOUBLE WELDED BOTTOM



3. MANHOLES STEPS AND LADDER – INJECTION MOLDED LADDER, WELDED IN THE ENTRANCE OF THE BODY OF MANHOLE.

Manholes steps and ladder shall conform to EN 14396 or to EN 13101 standard. They are positioned vertically and integrated in body structure to secure safe work during entrance inside in the manhole.

The structure strength of of the ladder is vertical load > 2 KN and pull out resistance is more than 6 KN.

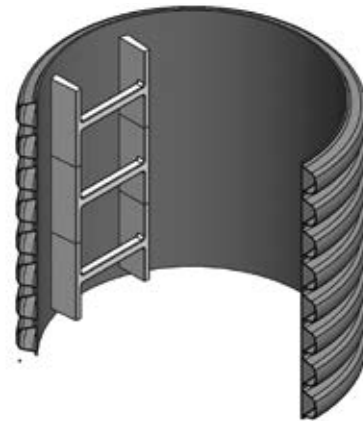
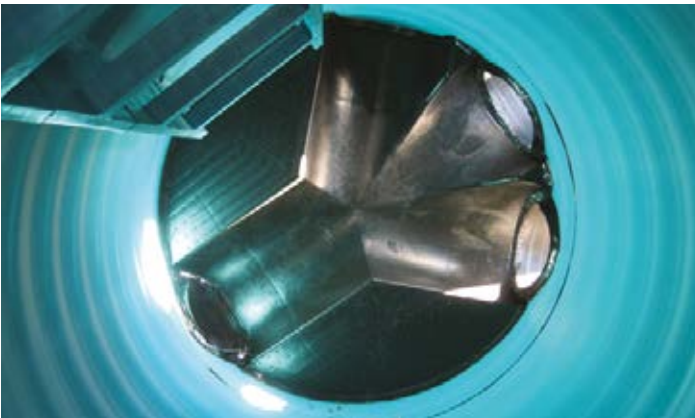

4. INJECTION MOLDED CONE

The Manhole is finished with injection molded cone. This part finishes the structure of the manhole and makes it a complete compact unit.

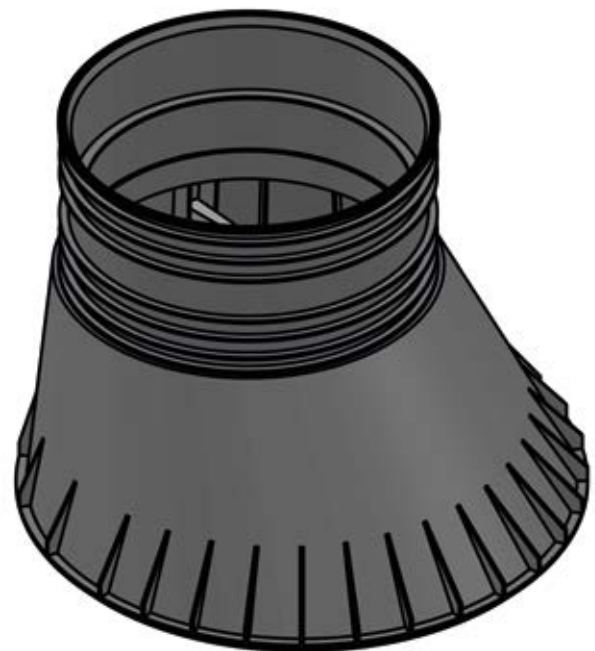

INSTALLATION OF MANHOLE CONNECTIONS



Cooperative parts on the manhole:
Bottom (base), Body and Conus



The base of the manhole is first set up



Above the bottom is placed the body from the ribbed tube, in a properly made groove for good setup with the bottom.



Installing the socket in any required position on the manhole. For good waterproofness, a rubber-flex adapter is first installed.



A plastic adapter is inserted to connect the pipe to the manhole.



This side connector is easily connected to the desired dimension.



Complete assembly of the socket in the manhole's body.



Side view of the socket.



The installation of the cone and the manhole is ready for the final internal welding of all joints.

KONTI SPIRAL MANHOLE

KONTI SPIRAL MANHOLE is made of spiral wounded pipe, made of same material as KONTI KAN Manhole, HDPE or PP.

This type of manhole is tangentially positioned related to the vertical pipe, which means it is moved from the middle. The tangential part of the manhole is made in diameters from ID1300 to ID 2000mm, and the vertical part is ID1000mm. The manholes are made from polyethylene, and the only difference is that the tangential pipe – the horizontal one is made of polyethylene/polypropylene – KK SPIRAL pipe.

The vertical part (the body) can be made in heights according to the requests of the buyer (10-12 m), and it can be made from spiral pipe or rotomolded parts. On the inside, it has built-in stairs. The upper part – the cover of the manhole is conically shaped eccentric opening.

The major advantage is a stable, flexible, low weight, easily accessible, self-cleaning and permanent construction.

COVER OF MANHOLE

Usually, the manholes are installed in a way so that the upper part of the manhole – the cover – is positioned on the upper edge of the field on top of which comes the concrete plate, which evens the load. The advantage of these manholes is that the outside load is not directly transferred to the manhole, but it is transferred through the concrete ring in the surrounding soil.

The manhole cover is also made of polyethylene, conically shaped with eccentric hole and there are two different heights of it available.

INSTALLATION OF PE/PP MANHOLES

PE/PP manholes installed in the earth behave similarly as PE/PP pipe. The manholes, pipes and connection parts are a single construction where stability and function safety are based on mutual functions of all integrated parts, bedding and filling. The site work, such as bedding, connection of manhole with pipes, side backfilling and main backfilling, make a compact system which insures proper function of the whole manhole system according to the standards' requirements.



RESISTANCE TO VERTICAL LOADING

As for the standard on pipes, a number of tests must be carried out to check the mechanical, physical and functional characteristics of manholes. The table indicates the mechanical tests for moulded bases as provided for by the EN 13598-1 standard.

CHARACTERISTICS	PRESCRIPTIONS	TEST PARAMETERS		TEST METHOD
		PARAMETERS	VALUES	
Stiffness of riser shaft	No cracking, stiffness \geq 0,7 kN/m ²	Shall conform to EN ISO 9969		EN ISO 9969
Vacuum requirement for resistance to ground and water pressure when installed		Temperature Test length Negative internal pressure	(23 \pm 2) ^o C 100 h -0.3 bar	EN ISO 13259
Resistance to vertical loading	Horizontal deflection not to exceed 6%. Deflection of cover shall conform to clause 4 of EN 1253 standard No cracking	Force per class L	15 kN	EN 1253-2

As for structured wall pipes, the jointing between the pipe and the manhole is subject to three different types of pressure:

- 0.05 bar corresponding to a standard operation;
- 0.5 bar corresponding to a peak flow rate;
- -0.3 bar corresponding to operation with groundwater.

CHARACTERISTICS	PRESCRIPTIONS	TEST PARAMETERS		TEST METHOD
		PARAMETERS	VALUES	
Watertightness	No leakage No leakage \leq - 0.27 bar	Temperature Spigot deflection Socket deflection Water pressure Water pressure Air pressure	(23 \pm 2) ^o C 10 % 5 % 0.05 bar 0.5 bar - 0.3 bar	EN ISO 13259 Cond. B

FLOTATION TEST

Plastic manholes installed in soils with groundwater are subject to an upward thrust equal to the volume occupied by water. It is therefore necessary to make a flotation test through the special characteristics of moulded bases (higher base circumference, rise composed of a corrugated pipe and the conical adapter with a large supporting surface) ensure the manhole stability.

The manhole stability is also ensured by other factors which should not be taken into consideration during the test:

- the weight of the load layer slab and the drain cover;
- the manhole own weight;
- the presence of inlet and outlet pipes which must be cut or removed before the manhole floats;
- the ground friction on the external surface;
- the ground weight on the horizontal projection.

In manholes, just like foundations, as depth increases the load is transferred on a larger surface.

Below is a description of the flotation test made on a DN/OD 1200 moulded base manhole, 2m high, where the sidefill has a specific weight of 21000 N/m³.

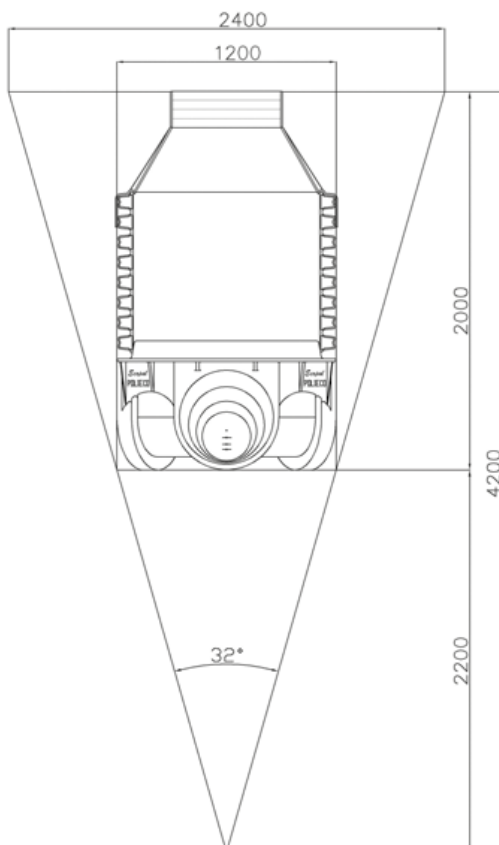

As a precaution, it was supposed that:

- the groundwater level reaches the soil surface;
- the friction angle is 16° (actually, the backfilling material to be used, sand or gravel, is between 25-34°);
- the manhole is empty.

The hydrostatic thrust is due to the weight of the water volume which is equal to the manhole volume; so

- volume of conical adapter: 0.19 m³
- rise and base volume: 1.56 m³

therefore, the hydrostatic thrust is 17.5 kN.

The stabilizing forces, are respectively, due to:

- the soil weight on the horizontal projection 5.39 kN
- the soil weight inside the corrugations 0.8 kN
- the weight of the surrounding soil cone 34.9 kN

The coefficient of safety due to the ratio between the stabilizing forces and the hydrostatic thrust is:

$$\Sigma W/S=2,35 (>2)$$

INSTALLATION OF MANHOLE

INSTRUCTIONS FOR INSTALLATION OF PE AND PP MANHOLE

Like the flexible pipes, the PE and PP manholes need a well compacted bedding and sidefill made with fine grain loose soil (coarse sand and fine gravel). (standard EN 1610).

This bedding must be accurately compacted to limit the settlement of the surface surrounding the manhole and compaction can be easily obtained using simple equipment for compaction.

Besides, the use of loose soil for the trench backfill eliminates the risk of road surface expansion and shrinkage due to the water content variation (variation of the groundwater levels) which is the main cause of road surface strain.

The dimensions of the separated material should be from 0 to 32 cm, and dimensions of the crushed material should be from 0 to 16 cm.

The surface should be made in layers of 15 to 20 cm and compacted to 97% by Procter.

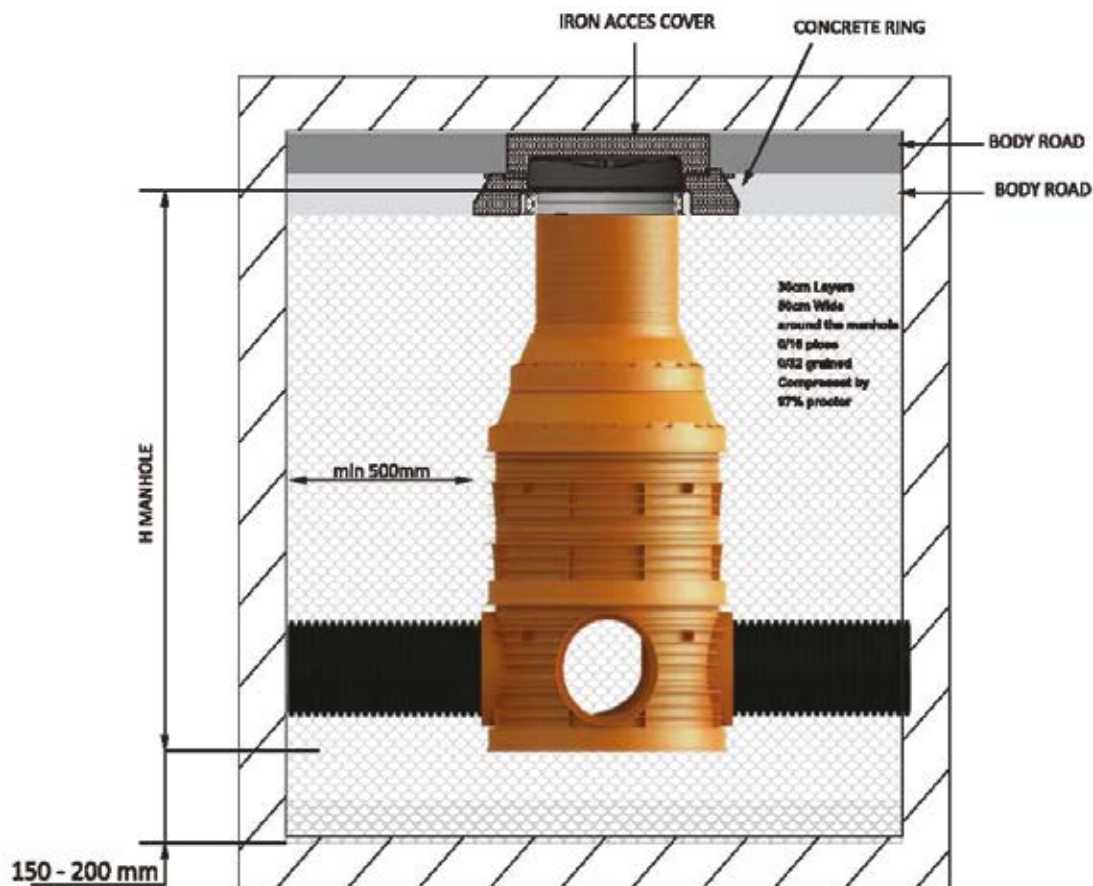

BEDDING AND BACKFILLING

You have to use same material as for the foundation, grained material has to be compacted by layers of 30 cm max, up to 97% of Procter, at least 50 cm wide from manhole.

Backfill, around and under the manhole is important to prevent possible deformation and leaning.

INSTALLATION OF PE AND PP MANHOLE IN PRESENCE OF UNDERGROUND WATER

In case of presence of groundwater, the surface should be 30 cm, made of concrete MB 15. Due to low weight manual installation is possible, in case of machine handling tying the ropes and ribbons is allowed only around the bottom, bases manhole or to apertures intended for it.

During installation work, excavation should be kept free of water e.g. rainwater, seepage water, spring water or water from leaks from pipeline. The method of dewatering is shown in the attached document according to EN 1610.

Precautions shall be taken to prevent loss of fine material during dewatering. The influence of dewatering on groundwater movement and stability of surrounding area shall be taken into account.

On completion of dewatering, any temporary drains shall be adequately sealed.



SET UP OF CONCRETE RING

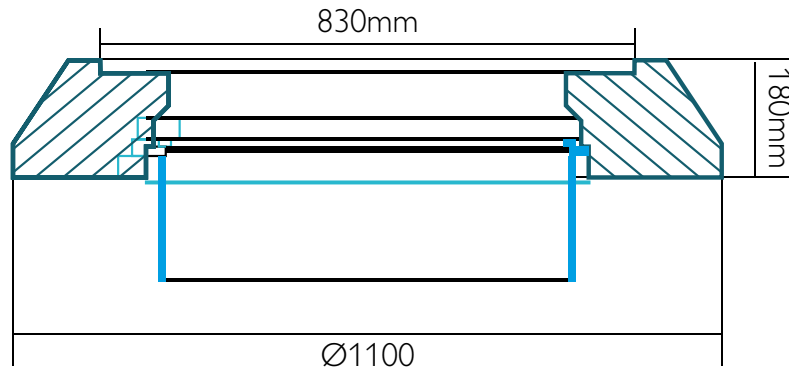

In case of heavy traffic, it is necessary to put a concrete ring on the cone. This concrete ring must not be in touch with the cone of the manhole. The empty space above the cone and the concrete ring should be 40mm, and between the cone and the ring a rubber is set up.

The cone should penetrate in the concrete ring 50mm.

In this way the static and dynamic burdening will not be transferred on the body of the manhole but on the pressed sand and the base around the manhole.

The concrete ring is not necessary in case of installation where there is no traffic and a direct polyethylene/ polypropylene cover or metal cover B 125 can be used.

STORAGE AND TRANSPORT INSTRUCTIONS

1. During storage and transport of manhole components, storing over sharp and spiny objects is not allowed therefore avoiding point overloading.
2. While unloading manholes from trucks, forklifts should be used assisted by straps, without throwing them from height.
3. While moving, pulling over sharp edges or sharp objects should be avoided.
4. Storage height depends on the geometry of the components, but heights above 2.5 m are not recommended.
5. The products can be stored outdoors because they have UV protection. If storage period is longer than 2 years, protection from direct sunlight is needed.
6. Freezing is not an issue for components of Interhol manholes because PE and PP are stable up to - 35°C. Although elasticity of rubber sealing rings might be reduced, which might cause installation difficulties.
7. Products should be kept out of contact with organic solvents and direct flame exposure.
8. Module components are delivered together.
9. Every components of the manhole has its ID number.

STANDARDS

The following international standard specifications are followed while producing HDPE manholes:

EN 13598 – 1 and 2: Plastics piping systems for non-pressure underground drainage and sewerage – (PVC-U), (PP) and polyethylene (PE) – **Part 2:** Specifications for manholes and inspection chambers in traffic areas and deep underground installations

ISO 9969: Thermoplastic pipes. Determination of Ring Stiffness

EN1610: Construction and testing of drains and sewers.

EN 13476-1: Plastics piping systems for non-pressure underground drainage and sewerage – Structured-wall piping systems of (PVC-U), (PP) and polyethylene (PE) – **Part 1:** General requirements and performance characteristics.

EN 13476-3: Plastics piping systems for non-pressure underground drainage and sewerage. Structured-wall piping systems of unplasticized poly(vinyl chloride) (PVC-U), polypropylene (PP) and polyethylene (PE). Specifications for pipes and fittings with smooth internal and profiled external surface and the system, Type B.

ENV 1046 – Plastics piping and ducting systems – Systems outside building structures for the conveyance of water or sewage – Practices for installation above and below ground;

EN 124-6:2015 – Gully tops and manhole tops made of polypropylene (PP), polyethylene (PE) or unplasticized poly(vinyl chloride) (PVC-U).

DIN 16961: Thermoplastic pipes and fittings with profiled outer and smooth inner surfaces.

DVS 2207-4: Welding of Thermoplastics. Extrusion welding panel and pipes.

ISO 13266:2010 – Thermoplastics piping systems for non-pressure underground drainage and sewerage – Thermoplastics shafts or risers for inspection chambers and manholes – Determination of resistance against surface and traffic loading.

EN 14982+A1 – Plastics piping and ducting systems – Thermoplastics shafts or risers for inspection chambers and manholes – Determination of ring stiffness.

EN 14830 – Thermoplastics inspection chamber and manhole bases – Test methods for buckling resistance.

EN 14396 – Fixed ladders for manholes.

EN 13101:2002 – Steps for underground man entry chambers – Requirements, marking, testing and evaluation of conformity.





**KONTI
HIDROPLAST®**



NORTH MACEDONIA
1480 Gevgelija, Industriska bb



+389 34 212 064 +389 34 215 225
+389 34 211 757 +389 34 215 226



+389 34 211 964



contact@konti-hidroplast.com.mk
hidroplast@t-home.mk



www.konti-hidroplast.com.mk



qualityaustria
SYSTEM CERTIFIED
ISO 9001:2008 No. 01442/0
ISO 14001:2004 No. 00211/0

EXACT

IG+

VORS
IQ

MDC

MAY, 2019

