



**KONTI**  
**HIDROPLAST®**

PRODUCTION OF POLYETHYLENE  
AND POLYPROPYLENE PIPES



**PE 80/100**  
**WATER SUPPLY**  
**POLYETHYLENE**  
**PIPES**

[www.konti-hidroplast.com.mk](http://www.konti-hidroplast.com.mk)



# CONTENTS

INTRODUCTION .....	2
GENERAL CHARACTERISTICS OF POLYETHYLENE PIPES .....	5
CLASSIFICATION OF PE FOR PRESSURE PIPES .....	6
EVALUATING A MATERIAL'S MRS USING THE ISO9080 STANDARD METHOD .....	7
MATERIAL LIFETIME ASSESSMENT OF PE 100 .....	7
KONTI HIDROPLAST'S CONCEPT FOR WATER PIPES .....	8
SDR – STANDARD DIMENSION RATION AND PRESSURE PIPE DESIGN .....	8
STRUCTURAL DESIGN OF BURIED PIPES, RING STIFFNESS AND NOMINAL STIFFNESS.....	10
BENDING RADIUS OF THE PE PIPES .....	11
HEAT INFLUENCE ON THE POLYETHYLENE PIPES.....	12
FLOW RESISTANCE OF POLYETHYLENE PIPELINES .....	15
USING A NOMOGRAM TO CALCULATE PRESSURE LOSS AND DIAMETER SIZE .....	16
MARKING A PIPE .....	17
HANDLING AND STORAGE .....	19
TRANSPORTATION .....	19
INSTALLATION .....	21
METHODS OF CONNECTING .....	21
BUTT WELDING .....	22
QUALITY STANDARDS AND SPECIFICATIONS .....	29
DESIGN OF THE PIPE BED AND SURROUNDING AREA FOR THE REGULAR PE 100 PIPELINES .....	32
CHEMICAL RESISTANCE .....	33
CERTIFICATES .....	36
LABORATORY TESTING .....	37



# *KONTI HIDROPLAST*®

## WELCOME TO OUR WORLD

Konti Hidroplast is part of the world's largest manufacturer and supplier of high performance plastic pipes and offers the best and the most cost effective pipe systems for its customers.

Konti Hidroplast specialises in polyethylene pipe systems for gas and water transportation in the utilities and industrial markets.

### MARKET ORIENTED

Konti Hidroplast products find a broad range of applications in the industrial and utilities market on a worldwide scale.

The water and gas distribution enterprises are important sectors for high integrity products where the maintenance of water quality and the safe transport of gaseous fuels are of paramount importance.

Industrial applications include alternative energy installations in landfill gas systems to effluent transportation and mineral slurry.

Products are widely used in pipeline installation, repair and maintenance.

Many of the brands in the Konti Hidroplast portfolio have a long record of innovation in meeting the needs of the water and gas utilities.

Being one of the foremost pioneers in polyethylene pipe systems, Konti Hidroplast is continually improving and updating its offer to meet the ever growing needs of the distribution engineer; ensuring they stay at the forefront of world gas and water distribution/treatment systems.





## CUSTOMER FOCUS

The key to our success lies in the commitment to provide the highest quality service and support. We are a team of highly motivated and experienced individuals.

We place the utmost importance on meeting the needs of our customers, constantly evolving our extensive product portfolio to meet the ever changing demands of the water and gas utilities, industrial and foreign markets.

## QUALITY

Konti Hidroplast is a result-driven business – its people, products and service. Designed, manufactured and supplied under EN ISO 9001:2000 accredited Quality Management Systems, Konti Hidroplast products comply with relevant national, European and international product standards to ensure complete reliability for our customers.

Besides the ISO certificates for Quality Management Systems and ecology, the gas pipes are also certified by DVGW CERT GmbH.

## THE ENVIRONMENT

Committed to sustainable manufacture and systems, Konti Hidroplast operates and maintains an environmental policy fully accredited by ISO 14001.

## GENERAL CHARACTERISTICS OF POLYETHYLENE PIPES

Pipes made of polyethylene have the following common characteristics:

- Low specific weight
- Flexibility
- Good chemical resistance
- Excellent welding capability
- Good resistance to earth movement
- Smooth inside surface with excellent resistance to deposits
- Food contact approval
- Long life (more than 50 years)
- Environmentally friendly, 100% recyclable

PE pipes have application in:

- Water supply systems
- Gas transportation
- Sewage systems
- Irrigation systems
- Protection of optical cables



## CLASSIFICATION OF PE FOR PRESSURE PIPES

The service life of a pipe depends on the conditions under which the pipeline operates, including load and environment.

By accelerated testing of polyethylene pipe material according to ISO/TR 9080, in order to predict the stress of the material after 50 years of usage at 20°C without any risks of decomposition, the following classification of polyethylene material for pressure pipes has been made:

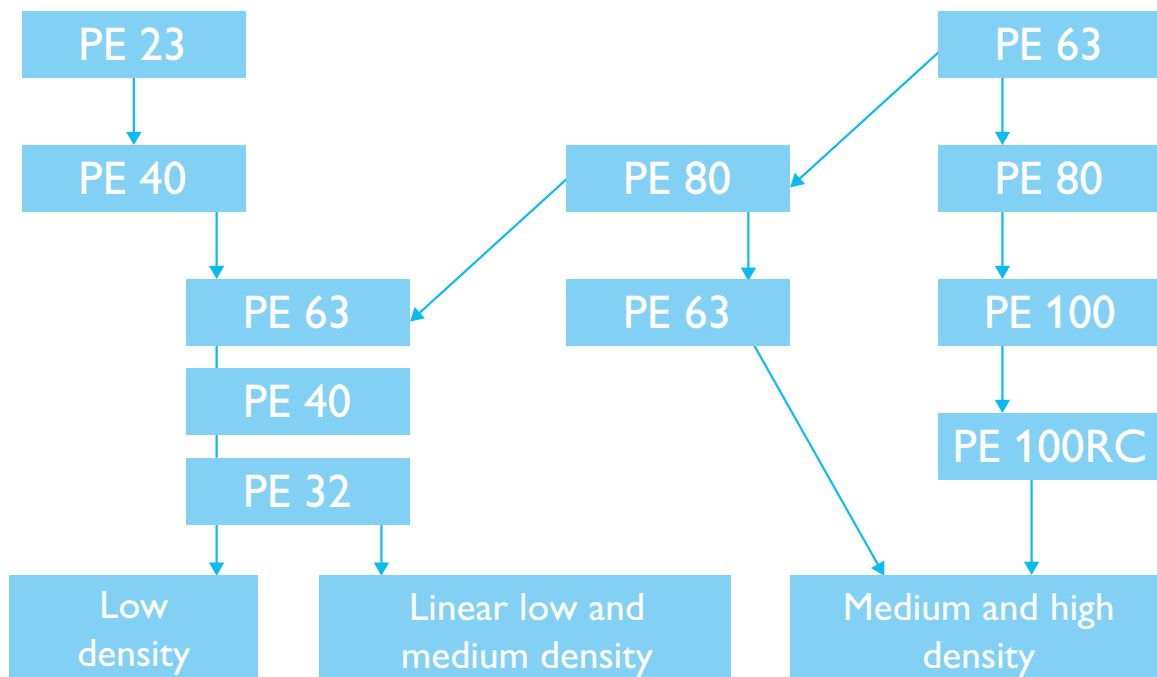

PE80-PE100 basic physical-mechanical characteristics of the materials at 23°C.

PROPERTIES	UNIT	STANDARD	VALUE	
			PE 80	PE 100
DENSITY	gr / cm <sup>3</sup>	ISO 1183	> 930	> 950
MELT FLOW INDEX (MFI)	g / 10 min (190° / 5 kg)	ISO 1133	0.4 - 0.8	0.2 - 0.4
ELONGATION	%	ISO 527	> 600	> 600
TENSILE STRENGTH	MPa	ISO 527	> 23	> 25
MODULE OF ELASTICITY	MPa	ISO 527	> 800	> 1000



# EVALUATING A MATERIAL'S MRS USING THE ISO9080 STANDARD METHOD

MRS is the continuous hoop stress that the PE must sustain after a 50-year-design life at a continuous temperature of 20°C.

High quality PE pipes can now sustain this stress after 100 years of lifetime.

A test is carried out at high temperatures to accelerate the aging.

1 year at 80 °C=100 years at 20 °C.

# MATERIAL LIFETIME ASSESSMENT OF PE 100

Material Lifetime Assessment – 100 years lifetime with modern high quality PE100.

$\sigma_{LPL}$  – lower confidence limit hydrostatic strength

50 years – 10,633 MPa

100 years – 10,50 MPa

High quality PE100 materials still exceed the MRS after 100 years of lifetime at 20°C.

Standard method: ISO 9080:2003(E)  
4 – parameters model

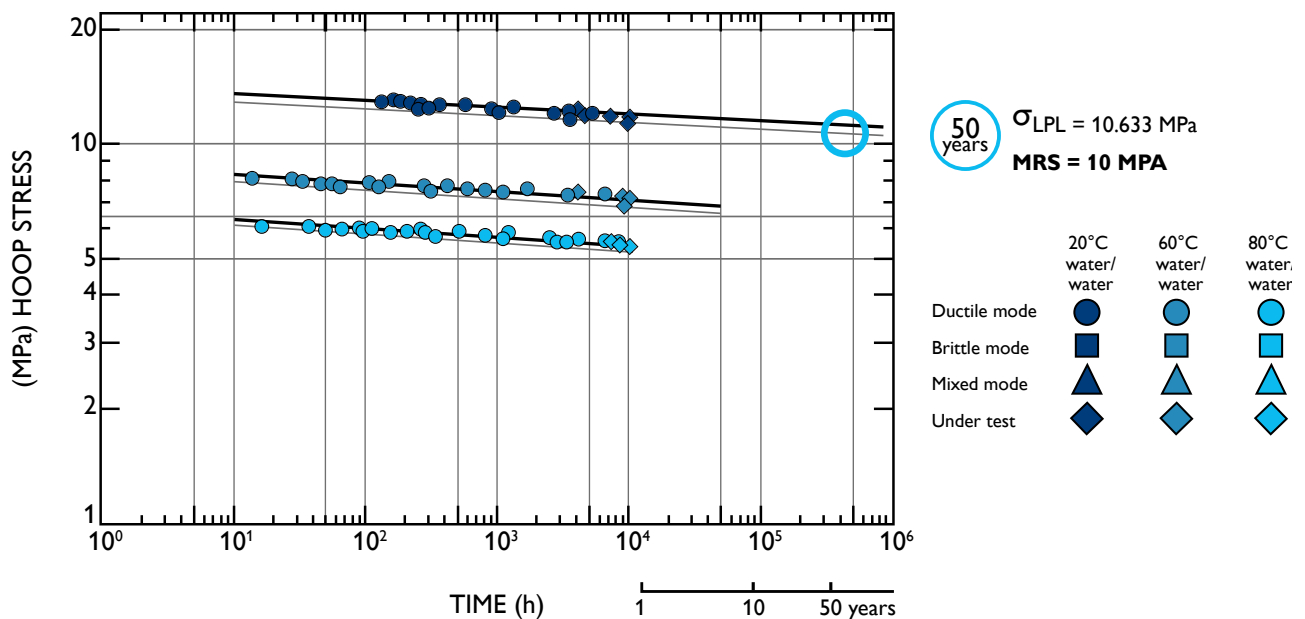

## KONTI HIDROPLAST'S CONCEPT FOR WATER PIPES

- The colour of the pipes is black with outside co-extruded blue lines, or all in blue. Sometimes by request can be made as coextruded pipe with inside white layer.
- The range of pipe diameters is DN 16 mm up to DN 800 mm and the pressure is PN 6 up to PN 32 bars.
- The pipes from the diameter range of 16-110 mm are flexible and they can be wound in coils of different lengths, hence the need for fittings and time for installation can be minimized.
- The pipes from the diameter range of 125-800 mm are produced in straight form pipes of 6 and 12 m length.

## SDR – STANDARD DIMENSION RATION AND PRESSURE PIPE DESIGN

One of the items of information contained on both pipe and fittings is the standard dimensional ratio.

In all but the smallest sizes of PE pipe (<25mm) the ratio between wall thickness and outside diameter remains constant for a given pressure rating of the pipe.

This relationship, called the standard dimensional ratio of SDR, can be expressed as an equation:

$$\text{SDR} = \frac{\text{NOMINAL (MINIMUM) OUTSIDE DIAMETER}}{\text{MINIMUM WALL THICKNESS}}$$

EXAMPLE:  $\text{SDR11} = \frac{180}{16.4}$

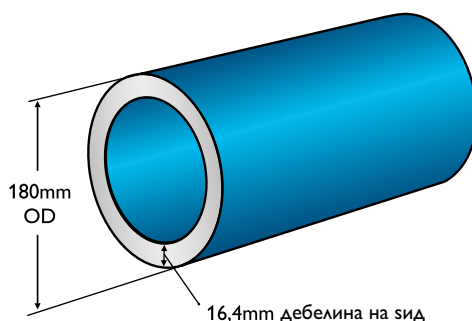
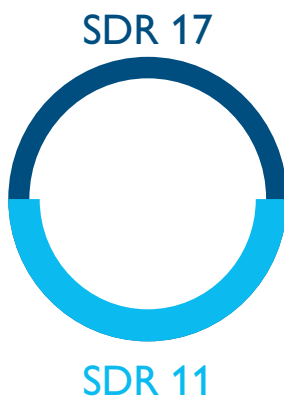

$$\sigma_h = \frac{(p \times d_m)}{(2 \times s)} \rightarrow \frac{P}{10} \times \frac{d_0 - s}{2 \times s}$$

$\sigma_h$  – hoop stress (N / mm<sup>2</sup>)

P – internal pressure (bar)

$d_m$  – mean pipe diameter (mm)

D – outside pipe diameter (mm)

s – wall thickness (mm)

Combining the equation for hoop stress and the SDR expression we get:

$$\sigma_h = \frac{P}{20} \times (\text{SDR} - 1) \quad \text{PN} = \frac{20 \times \text{MRS}}{(\text{SDR} - 1) \times S_f}$$

MRS – minimum required strength (MPa)

PN – pipe nominal pressure (bar)

$S_f$  – safety factor

Chart: PN, MRS, S and SDR relations at 20 °C and C=1.25 (for water)

SDR	S	NOMINAL PRESSURE (PN) BAR	
		PE 80	PE 100
41	20	3.2	4
33	16	4	5
26	12.5	5	6
21	10	6	8
17.6	8.3	-	-
17	8	8	10
13.6	6.3	10	12.5
11	5	12.5	16
9	4	16	20
7.4	3.2	20	25
6	2.5	25	32

TYPE	MIN. STRENGTH (MRS) MPa	$\sigma_s^a$ MPa
PE 100	10.0	8.0
PE 80	8.0	6.3
PE 63	6.3	5.0
PE 40	4.0	3.2

\* DESIGN TENSION ( $\sigma_s$ ), TOTAL DESIGN COEFFICIENT OR SAFETY FACTOR ARE DERIVED FROM MRS, WHEN C=1.25

NOTE: A BIGGER C VALUE CAN BE USED. FOR EXAMPLE, WHEN C=2 (FOR GAS), MAXIMUM DESIGN RESISTANCE  $\sigma_s$  VALUES MUST BE 4.0 MPa FOR PE80 AND 5.0 MPa FOR PE 100.

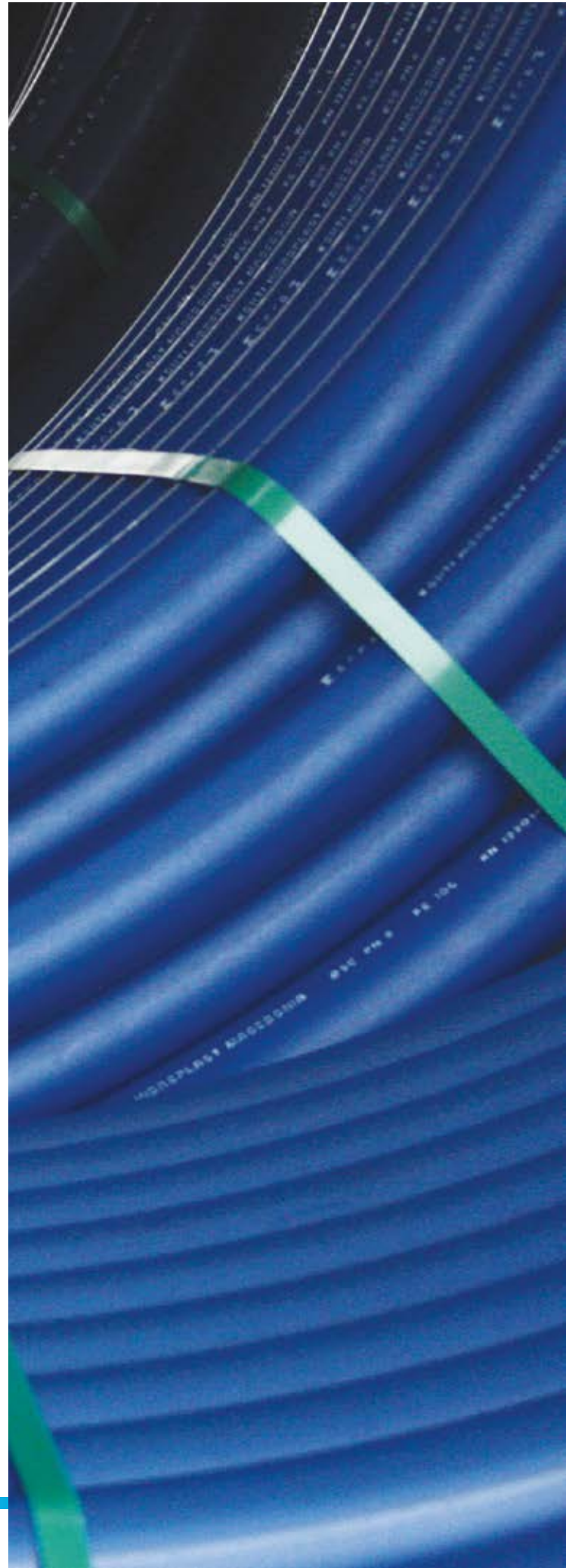

## STRUCTURAL DESIGN OF BURIED PIPES, RING STIFFNESS AND NOMINAL STIFFNESS

A pipe's ability to resist external loads is referred to as its ring stiffness

- THE PIPE RING STIFFNESS  $S = EI / D^3$

$I$  – pipe wall moment of inertia

( $I = e^3/12$  for solid walled pipes)

$e$  – wall thickness

$E$  – short term modulus of elasticity (Young's Modulus)

$D$  – mean pipe diameter

- "E" for PE 100 = ~ 1100 MPa
- Nominal stiffness (SN) is the pipe ring stiffness in MPa (KN/m<sup>2</sup>) divided by 1000

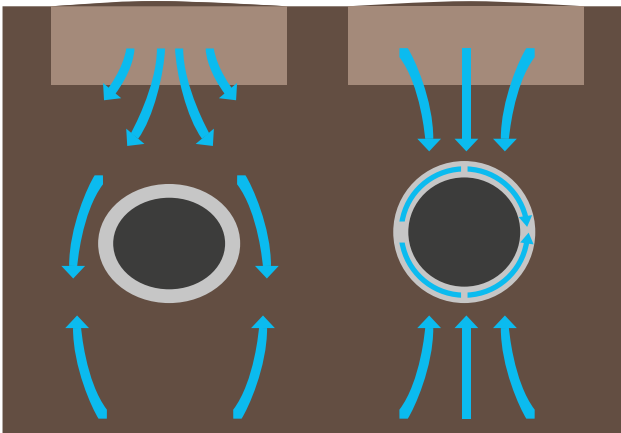

Pressure pipes have a very high ring stiffness.

Gravity pipe manufacturers and the standards refer to nominal pipe stiffness classes. Typically, SN 4 and SN 8 with SN 16 are the highest classes.

The pressure pipes have a relatively high wall thickness ( $e$ ) and, therefore, have a very high ring stiffness.

The gravity pipes' highest class is SN 16

- SDR 17 (PN 10) PE 100    SN 22
- SDR 11 (PN 16) PE 100    SN 92



Hence, in practice engineers do not consider the structural design of buried pipelines due to external loads, unless there are exceptional circumstances.

When distribution network pipes (not > OD315 mm) are laid beneath roads with less than 0.6 m cover, it is best to check the structural calculations.

## BENDING RADIUS OF PE PIPES

Polyethylene pipes are characterized by their flexibility, which, in turn, results in easy and fast installation, bypassing connection problems during installation and reducing the use of special fittings.

The following tables show the bending ability of the pipe relative to the nominal diameter, thickness ratio (SDR) as well as to the temperature.

SDR	BENDING RADIUS R DEPENDING ON OUTSIDE DIAMETER D <sub>n</sub>
41	50 D
33	40 D
26	30 D
17	20 D
11	20 D
7,4	20 D

BENDING RADIUS R DEPENDING ON TEMPERATURE			
T °C	PN 4	PN 6	PN 10
0 °C	≥ 75 D	≥ 60 D	≥ 50 D
10 °C	≥ 60 D	≥ 45 D	≥ 35 D
25 °C	≥ 45 D	≥ 30 D	≥ 20 D



## HEAT INFLUENCE ON POLYETHYLENE PIPES

Compared to many other materials, the polyethylene pipes reaction to thermal variations is much more visible. The coefficient of linear thermal dilatation is very high,  $2.0 \times 10^{-4} \text{ m/m}^\circ\text{C}$  at every  $1^\circ\text{C}$ .

The polyethylene is a material with a high coefficient of dilatation of  $2.0 \times 10^{-4} \text{ m/m}^\circ\text{C}^{-1}$ , meaning that one-meter pipe has a dilatation of 0.2 mm for each degree Centigrade increase of the temperature.

Calculation of dilatation:

$$\Delta L = L \times \Lambda \times \Delta t$$

Where:

$\Delta L$  – change in the pipe length

$\Lambda$  – coefficient of linear dilatation

$\Lambda = 0.2\text{mm/m}^\circ\text{C}$

$\Delta t$  – temperature differences between the expected working temperature and the temperature of installation (in  $0^\circ\text{C}$ )

The table below shows the elongation and shrinkage values (in mm) of polyethylene pipes during thermal variation

LENGHT OF THE PIPE (m)	THERMAL CHANGES ( $\Delta T$ ) $^\circ\text{C}$			
	10mm	20mm	30mm	40mm
1	2	4	6	8
6	12	24	36	48
12	24	48	72	96
50	100	200	300	400
100	200	400	600	800

## PRESSURE DECREASE FACTORS

If PE 100 and PE 80 pipe types are used permanently between 20°C and 40°C, the working pressure can be found by using the pressure lowering factors below:

Temperature (°C)	Factor (fT)
+20	1.00
+30	0.87
+40	0.74

For each temperature between the given values above, interpolation can be done.

The permitted working pressure (PFA) is found by this equation below:

$$PFA = fT \times fA \times PN$$

Where:

**fT** – Pressure decrease factor

**fA** – Decrease (or increase) factor due to application (for water transmission fA = 1)

**PN** – Nominal Pressure

## REQUIRED PIPE DIAMETER

Pipe sizes can be calculated for the given flow rate by the formulation below:

$$di = 18,8 (Q1/v)^{1/2} \text{ или } di = 35,7 (Q2/v)^{1/2}$$

Where:

**v** – flow speed (m/s)

**di** – pipe internal diameter (mm)

**Q1** – flow rate m<sup>3</sup>/h

**Q2** – flow rate l/s

**18.8** – conversion coefficient

**35.7** – conversion coefficient



## STANDARD VALUES FOR FLOW RATE

### Fluids

$V = 0,5-1,0$  m/s (for vacuum)

$V = 1,0-3,0$  m/s (for spreading)

### Gases

$V = 10-30$  m/s

The hydraulic losses have not been considered when calculating pipe diameters.

After the outer pipe diameter is determined, the real flow rate is calculated with the formula below:

$$V = 1275 (Q_2/d^2) \quad \text{or} \quad v = 354 (Q_1/di^2)$$

$v$  – flow rate (m/s)

$di$  – pipe internal diameter (mm)

$Q_1$  – flow rate  $m^3/h$

$Q_2$  – flow rate l/s

354 – conversion coefficient

1275 – conversion coefficient







## FLOW RESISTANCE OF POLYETHYLENE PIPELINES

The PE pipes belong to the category defined as “extremely smooth” and keep this condition when in operation, contrary to what may happen to the metal pipes.

There are many formulas to determine the flow resistance in the PE pipes.

As an indicator, we have chosen the Blasius formula with the relevant nomogram and table. The Blasius formula determines the pipeline flow resistance for water at 10°C.

$$h = \frac{\lambda V^2}{2gd}$$

Where:

**h** – flow resistance (m/100m)

**λ** – flow resistance coefficient

**V** – velocity (m/sec)

**g** – gravitational acceleration (m/sec<sup>2</sup>)

**d** – inside pipe diameter (mm)

The flow resistance coefficient **h** depends on the Reynolds number (**Re**)

$$Re = \frac{Vd}{\nu}$$

Where:

**ν** – kinematic viscosity of the fluid (m<sup>2</sup>/s)

## USING A NOMOGRAM TO CALCULATE PRESSURE LOSS AND DIAMETER SIZE

The nomogram below helps to determine the pressure loss per meter of pipe and the required diameter. To use the nomogram, at least two values must be known (for example: the internal diameter and the flow rate). Then, a line is drawn by two points. The point where the line intersects the P bend is the pressure difference for the pipe which the internal diameter has given.

For example, a line is drawn for both of the diameters on reductions and the P value is read. The difference between the P values shows the pressure loss.

Note: The pressure loss in this nomogram, suitable for fluids, has a density lower than 1000 kg/m<sup>3</sup> (e.g. water).

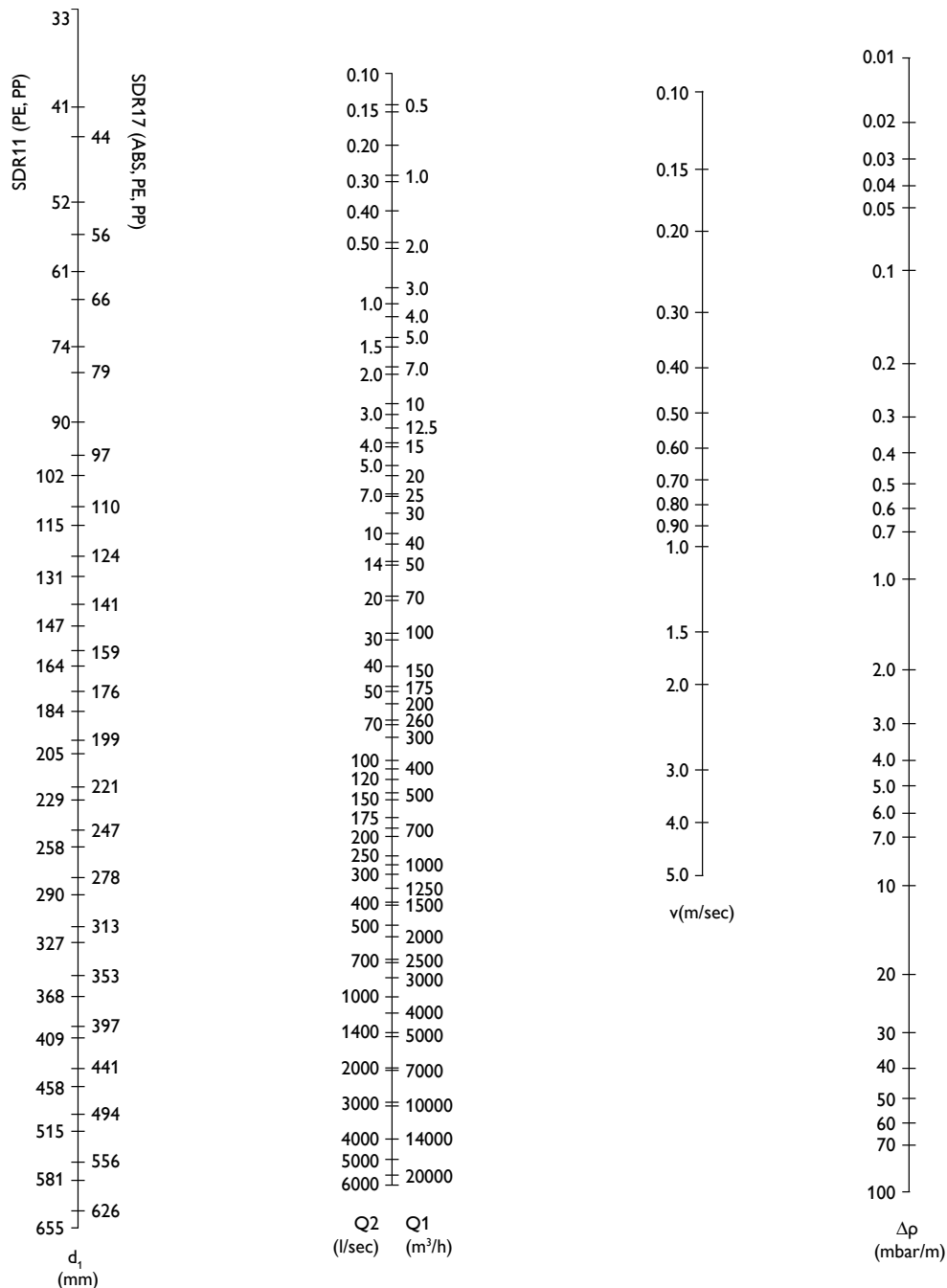

## MARKING A PIPE

The marking of the pipes, complies with ISO 4427/ EN 12201-2.

All pipes include clear, permanent marking at each meter length, made with ident printing in a colour contrasted to the pipe colour (white, black or yellow).

The following information is printed on the pipe:

- STANDARD  
e.g EN 12201-2 or ISO 4065
- Manufacturer name  
KONTI HIDROPLAST
- Nominal sizes  
(diameter x wall thickness)
- SDR serie
- Material designation  
e.g PE 100 /PE 80
- Pressure class  
e.g PN 10
- Production date and place
- Remaining length

Latest technologies for ident printing have been applied as well, using laser marking where a bar code having all the above information can be printed in 128 C in accordance with ISO 12176-4:2003 on the pipe.



## LASER BARCODE MARKING

### BARCODE EXAMPLE

KONTI HIDROPLAST	53102680	KONTI NUMBERS
COIL	2	PRODUCT TYPE (PIPE, COIL, PCS)
POTABLE WATER	1	PRODUCT APPLICATION
EN 12201-02:2011	01	PRODUCT STANDARD
DVGW	01	PRODUCT CERTIFICATION
SDR 17	06	SDR CLASS
Φ 63	07	DIMENSION
S = 3.8	072	WALL THICKNESS
PN 10	06	WORKING PRESSURE
PE 100	04	MATERIAL CLASIFICATION
CO-EXT	04	TYPE OF PRODUCTS (EXTRUSION, CO-EXTRUSION)
PRODUCTION LINE 4	04	NUMBER OF MACHINE
562	0182	WORKLIST NUMBER
MRS 10	2	MRS CODE
MFR 5 kg 0.2><0.35	5	MFR
BOREALIS HE3490 LS	0001	RAW MATERIAL CODE
15.03.2015	150315	PRODUCTION DATE DD/MM/Y
SHIFT NO.03	3	SHIFT

## HANDLING AND STORAGE

Transportation and storage of polyethylene pipes and fittings is an important issue for each type of installation. The transportation and the storage method is the same for all PE pipes because they have similar hardness. Although polyethylene is weak against sharp objects, it is a light, flexible and durable material which can be easily transported. Sharp objects must be kept away from pipes during transportation. Signs and explanations on the pipes should not exceed 10% of the outer diameter of the pipe. If they exceed 10% of the outer diameter, this kind of pipes must be considered as out of quality.

Generally, polyethylene pipes are not affected by low temperatures. However, because of the smooth surface of the polyethylene pipes and fittings, they become slippery and moist in cold air. Products should be kept in the packaging until usage. If the products are stored in open air for a long time, they should be covered with a canvas or a black polyethylene overlay in order to provide protection from the UV. In order to provide hygiene during storage, the open ends of the pipes should be covered against materials penetrating (soil, stone etc.).

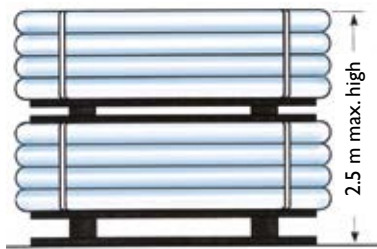

Frame packing of PE pipes

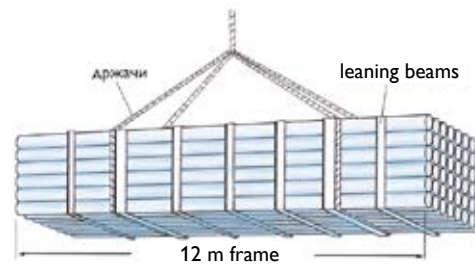

Handling of frame packaging via crane

## TRANSPORTATION

- If the load is carried in bulk, the loading surface of the vehicle should be smooth and free of sharp objects.
- Pipes and fittings must be carefully placed away from heat sources and from materials, such as oil, which may cause contamination.
- Metal chains and suspension straps must not directly contact the products during transportation. Straps made of polypropylene or nylon are recommended.
- Small fittings must be prevented from rubbing against other parts in order to avoid abrasion.
- Although special measures must be taken during horizontal transportation, pipes can be transported both vertically and horizontally.

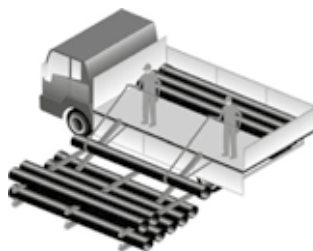

Unloading by using timbles slides



Wrong unloading

Fittings that are usually packed in cardboard boxes or bags should not be carried by hooks.

## STORAGE IN WAREHOUSES

All materials should be carefully examined during transportation and all flawed products should be identified before acceptance to the warehouse. The supplier should be notified about flawed products before acceptance.

If the same product is supplied by different suppliers, the products should be kept separately.

Pipes and fittings should be used through the First In – First Out (FIFO) principle, for better control of stocking rotations.

Only pipes from a known producer and with a known production date should be purchased and the pipes must be used according to the First In – First Out rule.

The blue polyethylene pipes should be kept under a cover and should not be exposed to direct sunlight until they are used.

If it is necessary to keep the pipes in the open air, pipes should be covered with a sun-proof (non-transparent) covers.

In order to store the pipes properly, a levelled surface should be provided which is capable of carrying the full load, necessary handling should be used and stacking heights should be kept at a minimum and an optimum. A safe area is needed for the maneuver of carriages. For a proper and safe transportation, the height of the stored pipe piles should not exceed 3 meters.

If the pipes are stored in a pyramid shape, the pipes at the bottom may be subject to deformation at moist air. Therefore, the height of the pyramid stacks should not exceed 1.2 meters.

Polyethylene fittings should be kept on shelves and under a cover. The protective package and the cardboard boxes used by the manufacturer should be kept until the use of the products.

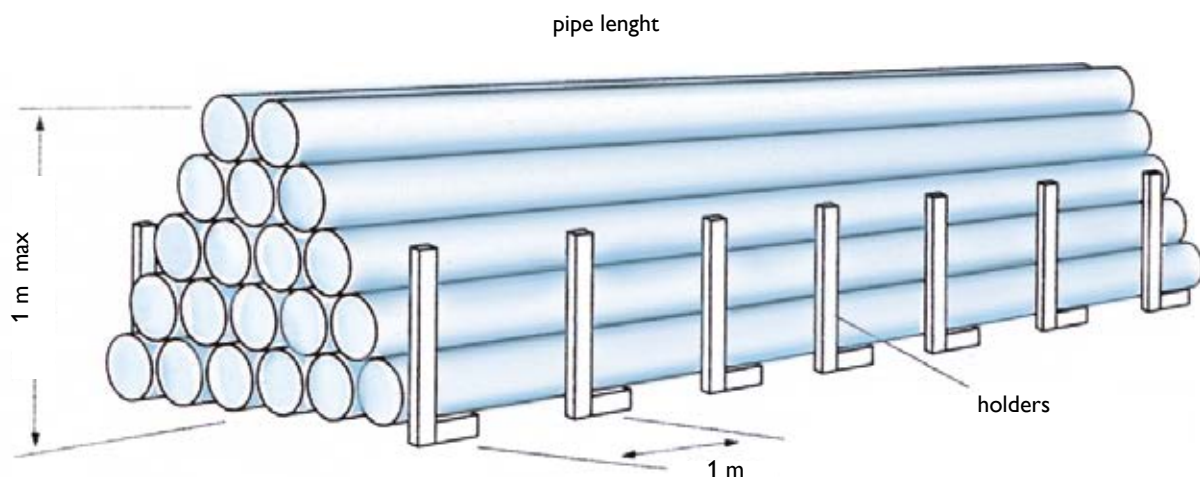

Pipes storage

Polyethylene pipes and fittings should always be stored away from heat sources and vehicle exhausts.

Polyethylene pipes and fittings should not be stored in the same place with machines that work with oil, hydraulic oils, gases, solvents and other flammable chemicals.

All the special tools and equipment used for connecting the polyethylene pipes and fittings should be kept separately and safely until used. The heating parts of the welding machines should be avoided since they can cause scratching during storage.

If it is necessary to store the pipes and fittings in the open air for a long time, they should be covered with canvas or black polyethylene in order to provide protection from sunlight (UV).

## INSTALLATION

For pipe installation, it is recommended that the pipes are placed into trenches at minimal depth of 45-60 cm, depending on the freezing zone. The installation of the pipes may be performed at air temperature of  $-5^{\circ}\text{C}$ .

## METHODS OF CONNECTING

The polyethylene can be connected in different ways. The most frequent are:

- Butt welding
- Electro fusion welding
- Mechanical connecting



## BUTT WELDING

The quality of butt welding directly depends on the operator's ability, the quality of the equipment and the supervisor who is responsible for the related standards. The process should be observed carefully from the beginning until the end. Before starting the butt welding process, it is important to check and verify all the parameters. Every operator should be educated and certified.

These issues should be considered before starting the welding process:

- The welding environment should be over +5°C and, if the weather is rainy or cold, it should be done in a sheltered area;
- Pipe ends should be closed to prevent air circulation and fast cooling;
- Before starting the welding process for coiled pipes, bending must be taken away from the pipes;
- The welding zone should be clean and undamaged.

### BUTT WELDING METHOD

The principle of the butt welding system is heating the welding surfaces for a certain time and pressuring the pipes with the same inner and outer diameter. The joining area of the welding components should be cleaned thoroughly and heated up to 200°C or 220°C. Then, the components are bonded together under certain pressure.

The welding pressure, the heat and the time should be properly chosen in order not to change the chemical and mechanical properties of the welded parts.

In the butt welding method, the butt areas are pressed on the heater plate, left at zero pressure until they reach the welding temperature and joined together under pressure (welding).

If the welding is well applied, the welded zone provides the same strength as the original pipe. In order to have a good-quality welding application, the butt welding pressure, the temperature and the time parameters should be set carefully.

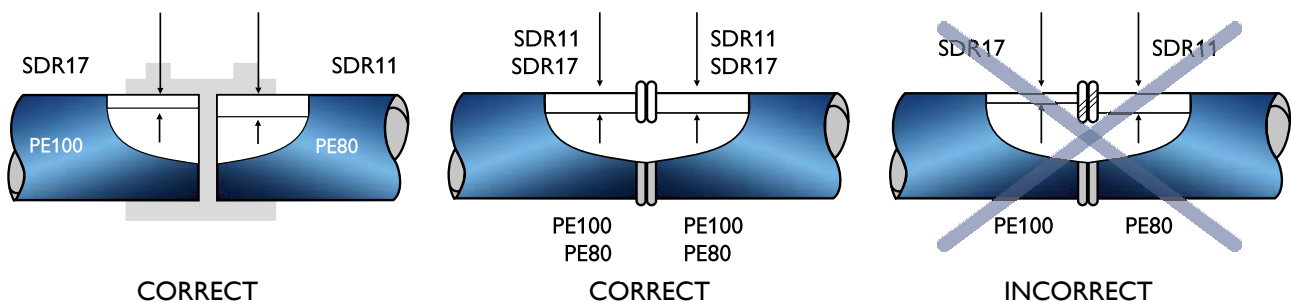

Pipes for butt welding



## BUTT WELDING PREPARATION

The temperature on the butt welding machine should be controlled just before starting the butt welding process. This must be done by an infrared thermometer. The heater plate should be left for a minimum of 10 minutes after reaching the set temperature. To insure an optimum welding quality, the heater plate has to be cleaned before every welding operation. The cleaning should be done by a soft cleaning material and alcohol. The heater plate (the Teflon coating) must be undamaged.

The joining forces and joining pressures have to conform to the machine working instructions. These can be based on the manufacturer's information or they can be calculated and measured. The moving pressure is taken from the indicators of the welding machine during the slow movement of the part to be welded. This value has to be added to the established joining pressure. The moving pressure may change depending on the machine, the pipe diameter and the pipe length. Therefore, before every welding process, the moving pressure should be read and added to the joining pressure.

The joining areas have to be planned before the butt welding. In this way, the pipes can be properly aligned and have a clean surface.

The gap width and the misalignment have to be controlled. Any misalignment must be avoided as much as possible. Even in the worst circumstances, it may not exceed 1/10 of the wall thickness.

The trimmed welding zones should not be touched and contaminated. Otherwise, trimming should be repeated. The shaving ribbons and other cut pieces must be cleared away from the welding zone without touching the trimmed faces.

## BUTT WELDING PROCESS

In the butt welding process, the welding zones are heated up to the welding temperature by the heater plate and the pipes are joined under pressure after removing the heater plate. The heating temperature should be 200°C to 220°C.

Higher temperatures are required for the thinner walls and lower temperatures for the thicker walls .

### REQUIRED TEMPERATURES FOR DIFFERENT WALL THICKNESSES

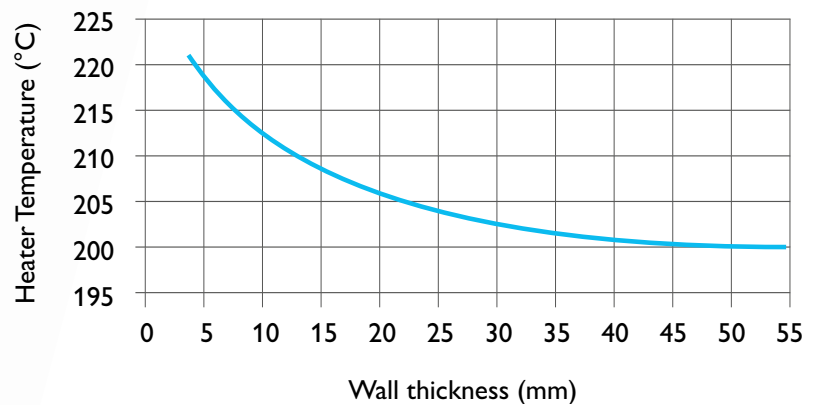

### REGIME OF HEATER PLATE SHAPED BUTT WELDING

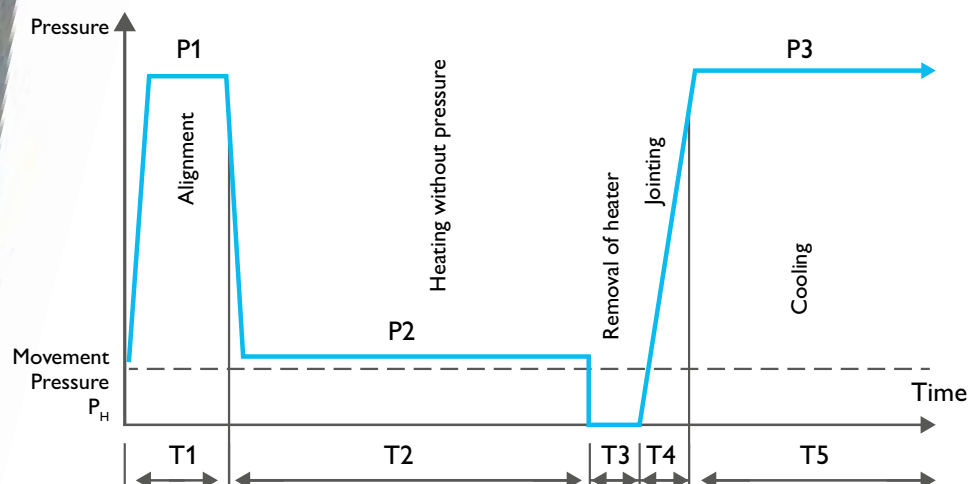

## HEATING UP WITHOUT PRESSURE

For heating up, the joining areas must contact the heater plate and the pressure must decrease. The pressure between the joining areas and the heater plate must be nearly zero ( $P_2=0.02 \text{ N/mm}^2$ ). At this time, the heat penetrates through the pipe axis. The heating up periods ( $T_2$ ) are mentioned in table 1, column 3. If a period lesser than the required is applied, the depth of the plastic part will be smaller than needed. As a result of this, the welding area will melt and corrode.

## REMOVAL OF THE HEATER PLATE

After heating up, the joining areas are to be detached from the heater plate. The heater plate should be carefully removed and the heated joining faces should be free of damage and contamination.

The joining areas should be joined together quickly after the removal of the heating tool. If the operator delays, the welding quality will be insufficient because of oxidation and cooling. The maximum time for this process is given in table 1, column 4.

## JOINING

After the heater plate is removed, the areas are aligned closer. There must be no strike or hit during this process. The required pressure time (interfaced pressure) is obtained linearly (graph 2). The required time ( $T_4$ ) is shown in table 1, column 5. The joining pressure ( $P_3$ ) is  $0,15 \pm 0,01 \text{ N/mm}^2$ .



Pipe alignment and joining, beads appear under pressure

## COOLING

The joining pressure ( $P_3$ -interfaced pressure) has to be kept during the cooling time. After the process, a regular double bead must appear. The bead size shows the regularity of the welding. Different beads could be caused by a different MFR (Melt Flow Rate) of the pipes. It must always be larger than 0 (see figure 6). The minimum time ( $T_5$ ) for this phase is given in table 1, column 5.

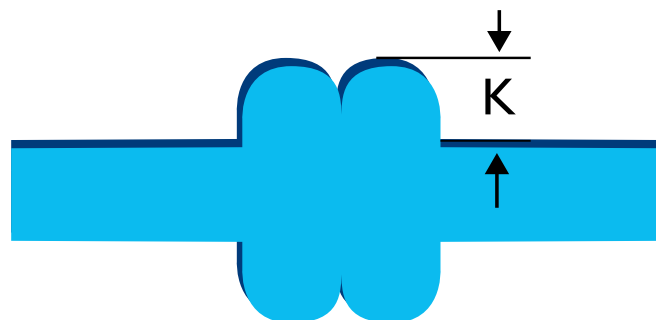

Cross section of beads

TABLE: SUGGESTED BUTT WELDING PARAMETERS FOR PE 100 PIPES AND FITTINGS

1	2	3	4	5	
NOMINAL WALL THICKNESS	ALIGNMENT (T1)	HEATING WITHOUT PRESSURE (T2)	REMOVAL OF HEATER (T3)	JOINING	
	BEAD HIGHT OF HEATED PIPE	HEATING UP TIME		JOINING TIME (T4)	COOLING TIME (T5)
mm	mm (min)	sec	sec (max)	sec	min (mm)
4.5	0.5	55	5	5	7
4.5 - 7	1.0	55 - 84	5 - 6	5 - 6	7 - 11
7 - 12	1.5	84 - 135	6 - 8	6 - 8	11 - 18
12 - 19	2.0	135 - 207	8 - 10	8 - 11	18 - 28
19 - 26	2.5	207 - 312	10 - 12	11 - 14	28 - 40
26 - 37	3.0	312 - 435	12 - 16	14 - 19	40 - 55
37 - 50	3.5	435 - 600	16 - 20	19 - 25	55 - 75
50 - 70	4.0	600 - 792	20 - 25	25 - 35	75 - 100

## STEP BY STEP BUTT WELDING PROCESS

1. Prepare the working site (e.g. cover the welding site)
2. Connect the welding equipment to the electrical net or the generator and test the function
3. Adjust the pipes with easy axial movement
4. Scrape the faces of the pipe or the fittings
5. Take the scraper off the welding machine
6. Remove the shaved parts from the welding area (use a brush or a paper towel)
7. Close the pipes' open ends to prevent air circulation
8. Check the alignment of the surfaces by bringing them together (misalignment must be maximum  $0,1 \times$  wall thickness)
9. Check the heater plate surface temperature
10. Clean the heater plate with a smooth and non-fuzzy rag or a paper towel
11. Read the moving pressure from the welding machine
12. Determine the value for aligning, heating up and joining pressures according to the producer's instructions
13. Apply the values to the machine according to the table
14. Set the heating tool to the welding position
15. Align the welding areas to the heating tool quickly and wait until minimum bead height occurs (according to table, column 2)

16. Decrease pressure to P2. This pressure is nearly zero 0.02 N/mm<sup>2</sup>. Wait during the time shown in the table, column 3, at P2 pressure
17. Remove the connection areas to be welded from the heater plate without damage and remove them from the welding position
18. The joining areas should be joined together immediately, within the time shown in the table, column 4. At contact, they have to meet with a speed of nearly zero and then build up a linear joining pressure P3 in the time shown in the table, column 5
19. After joining with a pressure of 0.15 N/mm<sup>2</sup>, a bead must appear. According to figure 6, K has to be > 0 on every section
20. Wait during the time shown in the table, column 5 for cooling
21. Remove the welded parts from the welding machine after the cooling has completed

## IMPORTANT ISSUES CONCERNING BUTT WELDING

- Materials to be welded should match each other.
- In order to maintain correct welding parameters at high humidity, extremely hot and windy working places should be protected from such weather conditions.
- Pieces should be protected from direct sunlight in order to keep the pipes at the same temperature.
- Pieces to be welded should be cleaned from dust, dirt etc.
- Pipes should be fastened carefully before welding. This is required both for an accurate centering and keeping the operator away from any harm during cutting and welding.
- During butt welding (cooling included), pieces should never face mechanical force or rupture.
- The other end of the welding pipe should be on a slippery surface to move freely. This is required to do back/forward feeding without applying any force on the welding area.
- The cutting tools should be with the required sharpness. The knives of the tools should be changed or sharpened at certain intervals.
- There should be no deep scratches, notches etc. on the Teflon surface of the heater. The surface of the heater should be checked occasionally.



Butt welding

## BUTT WELDING PROBLEMS AND POSSIBLE CAUSES

BEADS ARE TOO WIDE	OVERHEATING, OVER (ALIGNING) PRESSURE
GAP LENGTH BETWEEN BEADS IS TOO LARGE	OVER JOINING PRESSURE, INSUFFICIENT HEATING
	APPLYING PRESSURE DURING HEATING
BEADS'S UPPER SIDE IS TOO STRAIGHT	OVER JOINING PRESSURE, OVER HEATING
NOT UNIFORM BEAD AROUND THE PIPE	MISALIGNING, DEFECTED HEATER PLATE
BEADS ARE TOO SMALL	INSUFFICIENT HEATING, INSUFFICIENT JOINING PRESSURE
BEADS DO NOT OVERLAP ON THE PIPE'S OUTER SURFACE	GAP HEIGHT IS LOW; INSUFFICIENT HEATING AN INSUFFICIENT JOINING PRESSURE GAP HEIGHT IS HIGH; INSUFFICIENT HEATING AND OVER JOINING PRESSURE
BEADS ARE TOO LARGE	OVER HEATING
BEAD OUTER EDGE IS SQUARE	PRESSURE APPLIED DURING HEATING
ROUGH BEAD SURFACE	HYDROCARBON (SOIL) CONTAMINATION

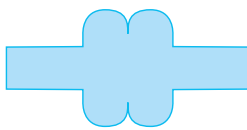

Proper welding



Over pressure and narrow bead width

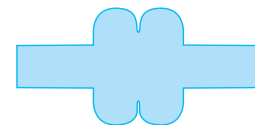

Split on the welding surface, low heating or long changing time

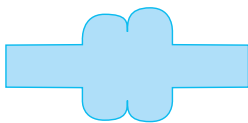

Different heating time and/or different heating temperature

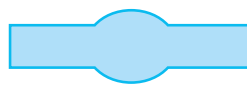

Low pressure and low bead height

## QUALITY STANDARDS AND SPECIFICATIONS

The quality of water pipelines based on PE pipes is imperative in every step of the way: starting from the production of the raw material, through pipe manufacturing and the final installation.

STANDARD NO.	STANDARD NAME
EN ISO 1167-1	THERMOPLASTICS PIPES, FITTINGS AND ASSEMBLIES FOR THE CONVEYANCE OF FLUIDS – DETERMINATION OF THE RESISTANCE TO INTERNAL PRESSURE –PART 1: GENERAL METHOD
EN ISO 1133	PLASTICS – THERMOPLASTICS – DETERMINATION OF THE MELT MASS-FLOW RATE (MFR) AND THE MELT VOLUME-FLOW RATE (MVR) OF THERMOPLASTICS
ISO 4065	THERMOPLASTICS PIPES – UNIVERSAL WALL THICKNESS TABLE
EN 681-2	ELASTOMETRIC SEALS – MATERIALS REQUIREMENTS FOR PIPE JOINTS SEALS USED IN DRAINAGE AND SEWERAGE APPLICATIONS – PART 2:THERMOPLASTIC ELASTOMERS
EN 713	PLASTIC PIPING SYSTEMS – MECHANICAL JOINTS BETWEEN FITTINGS AND POLYOLEFIN PRESSURE PIPES – TEST METHOD FOR LEAKTIGHTNESS UNDER INTERNAL PRESSURE OF ASSEMBLIES SUBJECTED TO BENDING
EN 715	THERMOPLASTIC PIPING SYSTEMS – END-LOAD BEARING JOINTS BETWEEN SMALL DIAMETER PRESSURE PIPES AND FITTINGS – TEST METHOD FOR LEAKTIGHTNESS UNDER INTERNAL WATER PRESSURE, INCLUDING END THURST
EN 12201-1	PLASTIC PIPING SYSTEMS FOR WATER SUPPLY – POLYETHYLENE (PE) – PART 1: GENERAL
EN 12201-2	PLASTIC PIPING SYSTEMS FOR WATER SUPPLY – POLYETHYLENE (PE) – PART 1: PIPES
EN 12201-3	PLASTIC PIPING SYSTEMS FOR WATER SUPPLY – POLYETHYLENE (PE) – PART 1: FITTINGS
EN 12201-4	PLASTIC PIPING SYSTEMS FOR WATER SUPPLY – POLYETHYLENE (PE) – PART 1: VALVES
EN 12201-5	PLASTIC PIPING SYSTEMS FOR WATER SUPPLY – POLYETHYLENE (PE) – PART 1: FITNESS FOR PURPOSE OF THE SYSTEM
CEN/TS 12201-7	PLASTIC PIPING SYSTEMS FOR WATER SUPPLY – POLYETHYLENE (PE) – PART 1: GUIDANCE FOR THE ASSESSMENT OF CONFORMITY
EN 805:2000	WATER SUPPLY. REQUIREMENTS FOR SYSTEMS AND COMPONENTS OUTSIDE OF BUILDINGS
ENV 1046:2002-04	ELASTIC PIPING AND DUCTING SYSTEMS – SYSTEMS OUTSIDE THE BUILDING TO TRANSFER WATER OR SEWAGE – PRACTICES FOR INSTALLATION ABOVE AND BELOW GROUND

## PE 80 - PIPES

STANDARDS:

EN 12201-2 / ISO 4427 / DIN 8074

DESIGN STRESS:  $\Delta = 6.3$  MPA

SAFETY FACTOR: C=1.25

COLOUR: BLACK WITH WHITE INSIDE LAYER AND  
COEXTRUDED BLUE LINES OR LIGHT BLUE WITH  
WHITE INSIDE LAYER

DN mm	SDR 33 <sup>1</sup> C 16 * PN 4		SDR 21 C 10 * PN 6		SDR 13.6 C 6.3 * PN 10		SDR 9 C 4 * PN 16		SDR 7.4 C 3.2 * PN 20		SDR 6 C 2.5 * PN 25	
	s (mm)	WEIGHT (kg / m)	s (mm)	WEIGHT (kg / m)	s (mm)	WEIGHT (kg / m)	s (mm)	WEIGHT (kg / m)	s (mm)	WEIGHT (kg / m)	s (mm)	WEIGHT (kg / m)
16	-	-	-	-	-	-	2.3	0.10	2.3	0.100	2.7	0.115
20	-	-	-	-	1.8	0.107	2.3	1.133	2.8	0.154	3.4	0.180
25	-	-	-	-	1.9	0.144	2.8	0.200	3.5	0.240	4.2	0.278
32	-	-	-	-	2.4	0.232	3.6	0.327	4.4	0.386	5.4	0.454
40	-	-	1.9	0.239	3.0	0.356	4.5	0.509	5.5	0.600	6.7	0.701
50	-	-	2.4	0.374	3.7	0.549	5.6	0.788	6.98	0.936	8.3	1.09
63	-	-	3.0	0.580	4.7	0.873	7.1	1.26	8.6	1.47	10.5	1.73
75	-	-	3.6	0.828	5.6	1.24	8.4	1.76	10.3	2.09	12.5	2.44
90	-	-	4.3	1.18	6.7	1.77	10.1	2.54	12.3	3.00	15.0	3.51
110	3.4	1.17	5.3	1.77	8.1	2.62	12.3	3.78	15.1	4.49	18.3	5.24
125	3.9	1.51	6.0	2.27	9.2	3.37	14.0	4.87	17.1	5.77	20.8	6.75
140	4.3	1.88	6.7	2.83	10.3	4.22	15.7	6.11	19.2	7.25	23.3	8.47
160	4.9	2.42	7.7	3.72	11.8	5.50	17.9	7.96	21.9	9.44	26.6	11.0
180	5.5	3.07	8.6	4.67	13.3	6.98	20.1	10.1	24.6	11.9	29.9	14.0
200	6.2	3.84	9.6	5.78	14.7	8.56	22.4	12.4	27.4	14.8	33.2	17.2
225	6.9	4.77	10.8	7.3	16.6	10.9	25.2	15.8	30.8	18.6	37.4	21.8
250	7.7	5.92	11.9	8.93	18.4	13.4	27.9	19.4	34.2	23.0	41.6	27.0
280	8.6	7.4	13.4	11.3	20.6	16.8	31.3	24.3	38.3	28.9	46.5	33.8
315	9.7	9.37	15.0	14.2	23.2	21.2	35.2	30.8	43.1	36.5	52.3	42.7
355	10.9	11.8	16.9	18.0	26.1	26.9	39.7	39.1	48.5	46.3	59.0	54.3
400	12.3	15.1	19.1	22.9	29.4	34.1	44.7	49.6	54.7	58.8	66.5	68.9
450	13.8	19.0	21.5	28.9	33.1	43.2	50.3	62.7	61.5	74.4	-	-
500	15.3	23.4	23.9	35.7	36.8	53.3	55.8	77.3	68.3	91.8	-	-
560	17.2	29.4	26.7	44.7	41.2	66.9	62.5	97.0	-	-	-	-
630	19.3	37.1	30.0	56.4	46.3	84.6	-	-	-	-	-	-
710	21.8	47.2	33.9	71.8	52.2	109	-	-	-	-	-	-
800	24.5	59.7	38.1	91.1	58.8	138	-	-	-	-	-	-

1) SDR 33 – pipes for drinking water supply systems are not produced

s – wall thickness

OD – outside diameter

\* Admissible operating pressure



## PE 100 - PIPES

STANDARDS:

EN 12201-2 / ISO 4427 / DIN 8074  
DESIGN STRESS:: = 8.0MPA

SAFETY FACTOR: C=1.25

COLOUR: BLACK WITH WHITE INSIDE LAYER AND  
COEXTRUDED BLUE LINES OR LIGHT BLUE WITH  
WHITE INSIDE LAYER

DN mm	SDR 41 <sup>2</sup> C 20 * PN 4		SDR 26 <sup>3</sup> C 12.5 * PN 6		SDR 21 C 10 * PN 8		SDR 17 C 8 * PN 10		SDR 13.6 C 6.3 * PN 12.5		SDR 11 C 5 * PN 16		SDR 9 C 4 * PN 20		SDR 7.4 C 4 * PN 25		SDR 6 C 2.5 * PN 32	
	s(mm)	WEIGHT (kg/m)	s(mm)	WEIGHT (kg/m)	s(mm)	WEIGHT (kg/m)	s(mm)	WEIGHT (kg/m)	s(mm)	WEIGHT (kg/m)	s(mm)	WEIGHT (kg/m)	s(mm)	WEIGHT (kg/m)	s(mm)	WEIGHT (kg/m)	s(mm)	WEIGHT (kg/m)
16	-	-	-	-	-	-	-	-	-	-	-	-	-	-	-	-	-	-
20	-	-	-	-	-	-	-	-	1.9	0.11	1.9	0.112	2.3	0.133	2.8	0.154	3.4	0.18
25	-	-	-	-	-	-	1.8	0.137	2.0	0.15	2.3	0.171	2.8	0.200	3.5	0.240	4.2	0.278
32	-	-	-	-	-	-	1.9	0.187	2.4	0.22	2.9	0.272	3.6	0.327	4.4	0.386	5.4	0.454
40	-	-	1.8	0.227	2	0.25	2.4	0.295	3.0	0.35	3.7	0.430	4.5	0.509	5.5	0.600	6.7	0.701
50	-	-	2.0	0.314	2.4	0.37	3.0	0.453	3.7	0.54	4.6	0.666	5.6	0.788	6.9	0.936	8.3	1.09
63	-	-	2.5	0.494	3	0.58	3.8	0.721	4.7	0.87	5.8	1.05	7.1	1.26	8.6	1.47	10.5	1.73
75	-	-	2.9	0.675	3.6	0.8	4.5	1.02	5.6	1.23	6.8	1.47	8.4	1.76	10.3	2.09	12.5	2.44
90	-	-	3.5	0.978	4.3	1.19	5.4	1.46	6.7	1.76	8.2	2.12	10.1	2.54	12.3	3.00	15.0	3.51
110	2.7	0.943	4.2	1.43	5.3	1.78	6.6	2.17	8.1	2.61	10.0	3.14	12.3	3.78	15.1	4.49	18.3	5.24
125	3.1	1.23	4.8	1.84	6	2.28	7.4	2.76	9.2	3.37	11.4	4.08	14.0	4.87	17.1	5.77	20.8	6.75
140	3.5	1.54	5.4	2.32	6.7	2.85	8.3	3.46	10.3	4.22	12.7	5.08	15.7	6.11	19.2	7.25	23.3	8.47
160	4.0	2.0	6.2	3.04	7.7	3.74	9.5	4.52	11.8	5.53	14.6	6.67	17.9	7.96	21.9	9.44	23.6	11.0
180	4.4	2.49	6.9	3.79	8.6	4.70	10.7	5.71	13.3	7.01	16.4	8.42	20.1	10.1	24.6	11.9	29.9	14.0
200	4.9	3.05	7.7	4.69	9.6	5.82	11.9	7.05	14.7	8.57	18.2	10.4	22.4	12.4	27.4	14.8	33.2	17.2
225	5.5	3.86	8.6	5.89	10.8	7.36	13.4	8.93	16.6	10.89	20.5	13.1	25.2	15.8	30.8	18.6	37.4	21.8
250	6.2	4.83	9.6	7.30	11.9	9.00	14.8	11.0	18.4	13.41	22.7	16.2	27.9	19.4	34.2	23.0	41.6	27.0
280	6.9	5.98	10.7	9.10	13.4	11.36	16.6	13.7	20.6	16.90	25.4	20.3	31.3	24.3	38.3	28.9	46.5	33.8
315	7.7	7.52	12.1	11.6	15	14.28	18.7	17.4	23.2	21.30	28.6	25.6	35.2	30.8	43.1	36.5	52.3	42.7
355	8.7	9.55	13.6	14.6	16.9	18.13	21.1	22.1	26.1	27.14	32.2	32.5	39.7	39.1	48.5	46.3	59.0	54.3
400	9.8	12.1	15.3	18.6	19.1	23.12	23.7	28.0	29.4	34.29	36.3	41.3	44.7	49.6	54.7	58.8	66.5	68.9
450	11.0	15.3	17.2	23.5	21.5	29.24	26.7	35.4	33.1	43.63	40.9	52.3	50.3	62.7	61.5	74.4	75.2	89.41
500	12.3	19.0	19.1	28.9	23.9	36.07	29.7	43.8	36.8	53.90	45.4	64.5	55.8	77.3	68.3	91.8	83.5	110.30
560	13.7	23.6	21.4	36.2	26.7	45.15	33.2	54.8	41.2	67.27	50.8	80.8	62.5	97.0	-	-	-	-
630	15.4	29.9	24.1	45.9	30	57.03	37.4	69.4	46.3	85.14	57.2	102	70.3	125.7	-	-	-	-
710	17.4	38.0	27.2	58.4	33.9	65.54	42.1	89	52.2	108.69	64.5	130	79.3	151.6	-	-	-	-
800	19.6	48.1	30.6	73.9	38.1	92.26	47.4	113	58.8	137.3	72.6	171.1	89.3	205.2	-	-	-	-

1) SDR 41 – pipes for drinking water supply systems are not produced

2) SDR 26 – not produced in coils

s – wall thickness

OD – outside diameter

\* Admissible operating pressure

## DESIGN OF THE PIPE BED AND SURROUNDING AREA FOR THE REGULAR PE 100 PIPELINES

The bed and the surrounding area should ideally comply with the UK water industry standard EN 805 and ENV 1046. Otherwise, it should be as follows:

- Gravel or broken stone graded 5-10 mm
- Coarse sand or a sand and gravel mix with gravel of less than 20 mm
- Good quality granular material, free of sharp stones or large lumps i.e. 20 mm or not bigger than the wall thickness
- Minimum compaction of 85%, standard Proctor density required

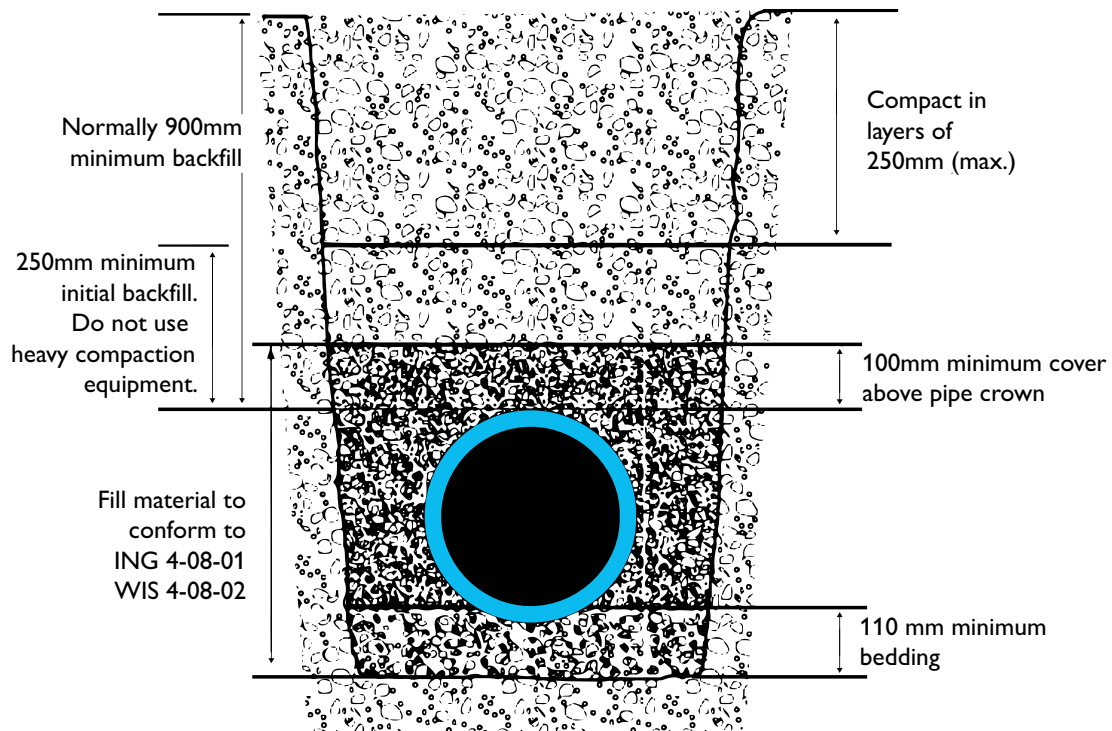

## CHEMICAL RESISTANCE

The table below shows the resistance of polyethylene against various chemicals at 23°C and 60°C. (+) signs in the table indicate that the polyethylene is resistant to chemicals, (/) means that the polyethylene has a limited resistance and (-) means that the polyethylene has no resistance against chemicals.

CHEMICAL	CON-CENTRATION %	CHEMICAL RESISTANCE	
		23°C	60°C
ACETIC ACID	100	+	+
ACETIC ANHYDRIDE	100	+	
ACETONE	100	+	+
AKKUMULATOR ACID	38	+	+
ALUMINIUM SALT, AQ	SAT	+	+
AMMONIA, AQ	SAT	+	+
AMMONIUM SALTS, AQ	SAT	+	+
AMYL ALCOHOL	100	+	+
ANILINE	100	+	+
ANTIFREEZE GLYCOL	50	+	+
ASPHALT	100	+	/
BARIUM SALTS, AQ	SAT	+	+
BARIUM SALTS, AQ	100	+	+
BENZALDEHYDE	100	/	-
BENZENE	100	+	/
BENZINE	100	+	/
BENZINE, NORMAL	100	/	-
BENZINE, SUPER	SAT	+	+
BENZOIC ACID, AQ	100	+	+
BONE OIL	SAT	+	+
BORAX, AQ	SAT	+	+
BORIC ACID, AQ	100	+	+
BREAK FLUID	100	-	
BROMINE	SAT	-	-
BROMINE WATER	100	+	
BUTANE, LIQUID	100	+	/
BYTYL ACETATE	100	+	+
BUTYL ALCOHOL, -N	SAT	+	+
CALCIUM SALTS, AQ	100	/	
CARBON DISULPHIDE	100	/	-
CARBON TETRACHLORIDE	SAT	+	+
CARBONIC ACID, AQ	50	+	+
CAUSTIC POTASH SOLUTION	100	/	-
CHLOROBENZENE	SAT	/	-
CHLORINE WATER	100	-	
CHLORINE, LIQUID	100	/	-
CHLOROFORM	100	-	-
CHLOROSULFONIC ACID	20	+	+
CHROMIUM SALTS, AQ	SAT	+	+
CHROMIUMTRIOXIDE, AQ	SAT	+	-
COOPER (III) - SALTS, AQ	SAT	+	+
CRESOL, AQ	SAT	+	/
CUMOLHYDROPEROXIDE	70	+	
CYCLOHEXANE	100	+	+
CYCLOHEXANOLE	100	+	+

CHEMICAL	CON-CENTRATION %	CHEMICAL RESISTANCE	
		23°C	60°C
CYCLOHEXANE	100	+	/
DECAHYDRONAPHTALENE	100	/	-
DETERGENTS, AQ	10	+	+
DIBUTYLPHTHALATE	100	+	/
DIBUTYLSEBACATE	100	+	/
DISEL OIL	100	+	/
DIETHYETHER	100	+	
DIHEXYLPHTHALATE	100	+	+
DISONONYLPHTHALATE	100	+	+
DIMETHYLFORMAMIDE	100	+	+
DINONYLADIPATE	100	+	
DIOCTYLADIPATE	100	+	
DIOCTYLPHTHALATE	100	+	+
DIOXANE, -1,4	100	+	+
ETHANOL	96	+	+
ETHANIL AMINE	100	+	+
ETHYL HEXANOL, -2	100	+	
ETHYL-2-HEXANE ACID	100	+	
ETHYL-2-HEXANE ACID CHLORIDE	100	+	
ETHYL-2-HEXYL CHLOROFORMIAT	100	+	
ETHYLACETATE	100	+	/
ETHYLBENZENE	100	/	-
ETHYLCHLORIDE	100	/	
ETHYLENE CHLORHYDRIN	100	+	+
ETHYLENE CHLORIDE	100	/	/
ETHYLENE DAIMINETETRAACETIC ACID, AQ	SAT	+	+
ETHYLGLYKOLACETATE	100	+	
FATTY ACIDS > C6	100	+	/
FERROUS SALT, AQ	SAT	+	+
FLOOR POLISH	100	+	/
FLOURIDE, AQ	SAT	+	+
FLUOSILICIC ACID	32	+	+
FORMALDEHYDE, AQ	40	+	+
FORMALIN	INDUST.	+	+
FORMIC ACID	98	+	+
FRIGEN 11	100	/	
FUEL OIL	100	+	/
FURFURYL ALCOHOL	100	+	/
GLYCERINE	100	+	+
GLYCERINE, AQ	10	+	+
GLYCOL	100	+	+
GLYCOL ACID	70	+	+
GLYCOL, AQ	50	+	+
HEPTANE	100	+	/
HEAFLUOSILICIC ACID, AQ	SAT	+	+

CHEMICAL	CON-CENTRA-TION %	CHEMICAL RESISTANCE	
		23°C	60°C
HEXANE	100	+	+
HUMIC ACIDS, AQ	1	+	+
HYDRAZINE, AQ	SAT	+	+
HYDRIODIC, AQ	SAT	+	
HYDROCHINONE, AQ		+	
HYDROCHLORIC ACID	38	+	+
HYDROCHLORIC ACID	10	+	+
HYDROCHLORIC ACID	40	+	+
HYDROCHLORIC ACID	70	+	/
HYDROGEN PEROXIDE	30	+	+
HYDROGEN SULPHIDE	LOW	+	+
HYDROXYLAMMONIUM SULPHATE	SAT	+	+
HYDROXYACETONE	100	+	+
ISONONAN ACID	100	+	/
ISONONAN ACOD CHLORIDE	100	+	
ISOCTANE	100	+	/
ISOPROPANOL	100	+	+
LACTIC ACID, AQ	90	+	+
LAURIC ACID CHLORIDE	100	+	
LITHIUM SALTS	SAT	+	+
LYSOL	INDUS.	+	/
MAGNESIUM SALTS, AQ	SAT	+	+
MENTHOL	100	+	
MERCURIC SALTS, AQ	SAT	+	+
MERCURY	100	+	+
METHAN SUPHONIC ACID	50	+	
METHANOL	100	+	+
METHOXYL BUTANOL	100	+	/
METHOXY BUTIL ACETATE	100	+	/
METHYL CYCLOHEXANE	100	+	/
METHYL ETHYL KETONE	100	+	+
METHYL GLYCOL	100	+	+
METHYL ISOBUTYL KETONE	100	+	/
METHYL SULPHURIC ACID	50	+	
METHYL-4-PENTANOL-2	100	+	+
METHYLACETATE	100	+	+
METHYLENE CHLORIDE	100	/	
MINERAL OIL	100	+	/
MONOCHLORACETIC ACID ETHYL ESTER	100	+	+
MONOCHLORACETIC ACID METHYL ESTER	100	+	+
MORPHOLINE	100	+	+
MOTOR OIL	100	+	/
NA-DODECYL BENZ. SULPHON	100	+	+
NAIL POLISH REMOVER	100	+	/
NEODECANA ACID	100	+	

CHEMICAL	CON-CENTRA-TION %	CHEMICAL RESISTANCE	
		23°C	60°C
NEODECANA ACID CHLORIDE	100	+	
NICKEL SALTS, AQ	SAT	+	+
NITRIC ACID	50	/	/
NITRIC ACID	25	+	+
NITROBENZENE	100	+	/
NITROHYDROCHLORIC ACID HCl:HNO3	3:1	+	-
NITROMETHANE	100	+	
OILS, ETHERIAL		+	
OILS, VEGETABLE	100	+	+
OLEIC ACID	100	+	/
OLEUM	>100	-	-
OXALIC ACID, AQ	SAT	+	+
PARAFIN OIL	100	+	/
PARALDEHYDE	100	+	
PCB	100	/	
PECTIN	SAT	+	+
PERCHLORETHYLENE	100	/	-
PERCHLORIC ACID	20	+	+
PERCHLORIC ACID	50	+	/
PERCHLORIC ACID	70	+	-
PETROLEUM	100	+	/
PETROLEUM ETHER	100	+	+/
PHENOL, AQ	SAT	+	+
PHENYLCHLOROFORM	100	/	/
PHOSPHATES, AQ	SAT	+	+
PHOSPHORIC ACID	85	+	+
PHOSPHORIC ACID	50	+	+
POTASSIUM PERMANGANATE, AQ	SAT	+	+
POTASSIUM PERSULPHATE, AQ	SAT	+	+
POTASSIUM SALT, AQ	SAT	+	
POTASSIUM SOAP	100	+	/
PROPANE, LIQUID	100	+	+
PYRIDINE	100	+	+
SALAD OIL	100	+	+
SALTED WATER	SAT	+	/
SEA WATER		+	+
SHOE POLISH	100	+	+
SILICONE OIL	100	+	+
SILVER SALTS, AQ	SAT	+	+
SOAP SOLUTION	SAT	+	+
SOAP SOLUTION	10	+	+
SODA LYE	60	+	+
SODIUM CHLORATE, AQ	25	+	+
SODIUM CHLORITE, AQ	5	+	/
SODIUM HYPOCHLORITE, AQ	5	+	+

CHEMICAL	CON- CENTRA- TION %	CHEMICAL RESISTANCE	
		23°C	60°C
SODIUM HYPOCHLORITE, AQ	30	/	/
SODIUM HYPOCHLORITE, AQ	20	+	+
SODIUM SALTS, AQ	SAT	+	+
SUCCINIC ACID, AQ	SAT	+	+
SULPHUR DIOXIDE, AQ	LOW	+	+
SULPHURIC ACID	96	-	-
SULPHURIC ACID	50	+	+
TANNIC ACID	10	+	+
TAR	100	+	/
TARTARIC ACID, AQ	SAT	+	+
TEST FUEL, ALIPHATIC	100	+	/
TETRACHLORETHANE	100	/	-
TETRACHLORETHYLENE	100	+	-
TETRAHYDRO NAPHTHALENE	100	/	-
TETRAHYDROFURAN	100	/	-
THIOPHENE	100	+	/
TIN-II-CHLORIDE, AQ	SAT	/	+
TOLUENE	100	+	-
TRANSFORMER OIL	100	/	/
TRICHOLORETHYLENE	100	+	-
TRICRESYL PHOSPHATE	100	+	+
TWO-STROKE OIL	100	+	/
UREA, AQ	SAT	+	/
URIC ACID	SAT	+	+
URINE		+	+
WASHING-UP LIQUID FLUID	5	+	+
WATER GASS	100	+	+
WETTING AGENT	100	+	/
XYLENE	100	/	-
ZINC SALTS, AQ	SAT	+	+

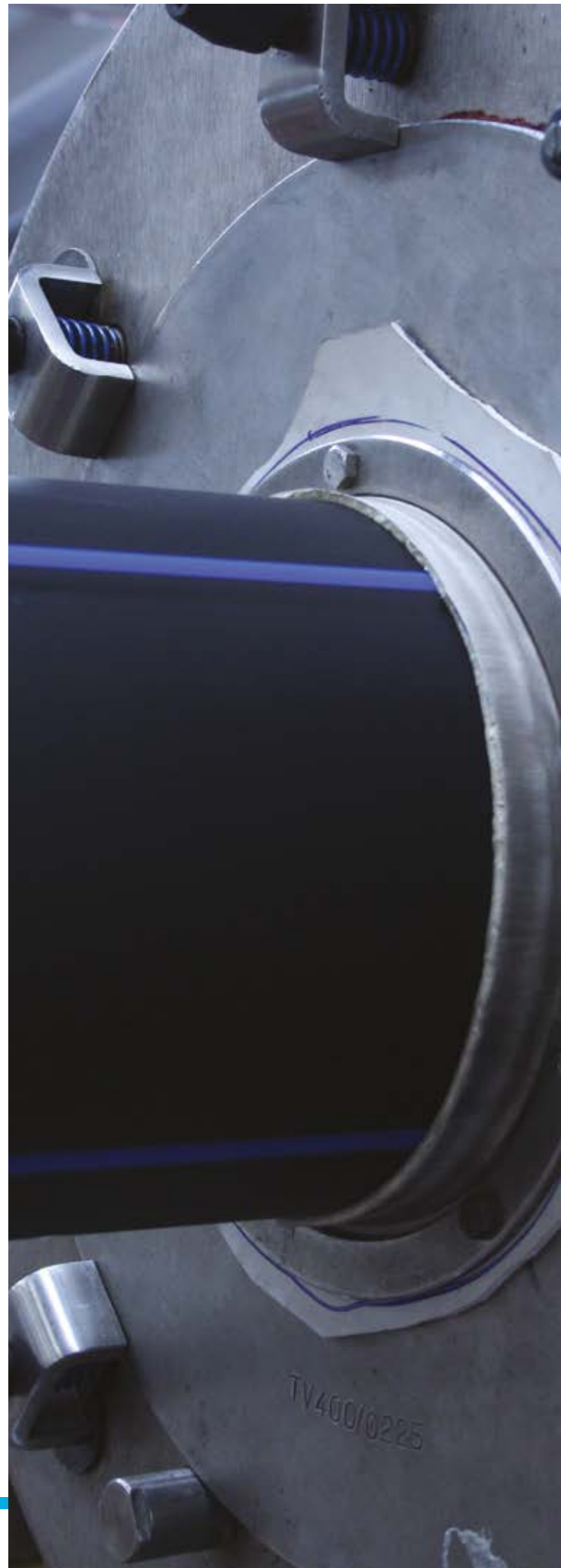

# CERTIFICATES



## LABORATORY TESTING

### MELT MASS-FLOW RATE



### VOLATILE CONTENT

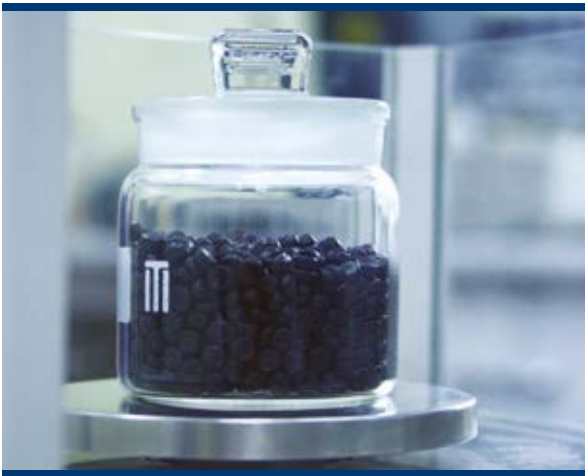

### DENSITY



### ELONGATION AT BREAK



### HYDROSTATIC STRENGTH AT 80° AND 20° C





**KONTI  
HIDROPLAST®**



NORTH MACEDONIA  
1480 Gevgelija, Industriska bb



+389 34 212 064 +389 34 215 225  
+389 34 211 757 +389 34 215 226



+389 34 211 964



contact@konti-hidroplast.com.mk  
hidroplast@t-home.mk



www.konti-hidroplast.com.mk



MAY, 2019